

SENSITIVITY ANALYSIS FOR INTEGRATION OF RENEWABLE ENERGY SOURCES INTO DISTRICT HEATING SYSTEMS

by

Igor SHESHO*, **Elena LAZOVA KOCHOV**,
Monika ULER-ZEFIKJ, and **Risto FILKOSKI**

Faculty of Mechanical Engineering, Ss. Cyril and Methodius University in Skopje,
Skopje, North Macedonia

Original scientific paper
<https://doi.org/10.2298/TSCI240528236S>

The advantage of district heating systems compared to individual systems lies in their potential to diversify heat sources, foster greater system independence and reliability, and optimise heat energy production costs. This work evaluates the techno-economic rationale behind investing in district heating systems focusing on determining the threshold at which such investments become cost-effective. This includes indicators such as linear heat density (MWh/km) to ascertain the break-even point, alongside the calculation of the levelized cost of energy. Five simulation models of a heating system are developed and analysed for a designated area of the city of Ohrid (Republic of North Macedonia), focusing on existing buildings and their energy consumption patterns. Three scenarios incorporate public facilities such as schools, offices, and hospitals. Additionally, two more scenarios include these facilities along with 1000 residential buildings to achieve higher linear heat density. These buildings are examined both as energy class D structures with a demand of 110 kWh/m² per year and as more efficient energy class C buildings with a heat demand of 70 kWh/m² per year, including for space heating and domestic hot water supply. The energy hub system integrates various components, such as solar thermal collectors, combined heat and power, and heat pumps, to meet heat demands while ensuring a balanced energy mix. Scenario 5 is identified as the most cost-effective, with a levelized cost of energy of 98 EUR/MWh, a linear heat density of 1363 MWh/km, and an annual heat demand of approximately 15 GWh.

Key words: *district heating, renewable energy sources, energy modelling, optimisation*

Introduction

According to the latest IEA's World Energy Outlook 2023 [1], heating, including space and water heating, constitutes approximately 45% of energy demand and contributes to 80% of direct CO₂ emissions from buildings. In the stated policies scenario, fossil fuels meet 50% of heating demand by 2030 and 35% by 2050, with emissions still reaching 1.5 Gt CO₂ annually by 2050. Conversely, the net-zero-energy scenario achieves full decarbonisation of heating through electrification, renewables, and district heating (DH), along with efficiency enhancements, particularly through adopting heat pumps. In 2021, global heat energy generated by district heating systems (DHS) amounted to approximately 16 EJ, marking a 10% rise compared to ten years ago [2]. In 2022, heat production remained broadly consistent with

* Corresponding author, e-mail: igor.seso@mf.edu.mk

the previous year, satisfying around 9% of the global final heating demand in buildings and industry. Despite the ongoing global expansion of DHS, the opportunity for decarbonization by incorporating RES and system optimisation remains vastly underutilised. Notably, almost 90% of global heat energy in 2021 and 2022 originates from fossil fuels, with coal (over 45%) predominating, particularly in China, natural gas (around 40%) in Russia, and oil (3.5%) [2]. As of 2022, natural gas remains the predominant energy source for heating in buildings worldwide, satisfying 42% of heating demand. The distribution of natural gas usage varies, with the USA relying on it for over 60% of its heating needs, while the EU and China utilise it for approximately 40% and 20% of their heating requirements, respectively. In China, coal's direct use for heating has declined by nearly 50% over the past five years. However, it still contributes around 18% to energy demand, supplemented by its dominant role in DH networks, constituting over 80% of the fuel mix. Oil, primarily utilised for water heating, accounts for 15% of global heating energy usage, notably in countries with lower space heating demands, such as Indonesia, Mexico, and Chile [3]. The previous analysis clearly indicates the need for a more serious integration of renewable energy resources in heat energy supply systems.

As stated in the latest EuroHeat and Power report called 2023 DHC Market Outlook Insights and Trends [4], at the EU level, DH accounts for approximately 12% of the final energy utilised for space and water heating, with over 17000 DH networks serving a population of 70 million individuals and sales reaching close to 500 TWh in 2021. The European DH sector encompasses a total installed capacity of around 300 GWth, with Poland and Germany leading in installed capacities, followed by several other countries, where by far the largest part of the energy needs is covered by the use of fossil fuels. Notably, Iceland boasts a remarkable 93.4% share of renewable heat, primarily from geothermal sources. Combined heat and power (CHP) play a significant role within the European DH sector, representing over 66% of total district heat production in many European countries.

In 2022, global heat pump sales experienced an 11% increase, marking the second consecutive year of double-digit growth for this pivotal technology in the worldwide shift towards secure and more sustainable heating solutions. In Europe, the heat pump sales surged by nearly 40%, with air-to-water models suitable for conventional radiators and underfloor heating systems witnessing an almost 50% rise in demand [5].

The EU aims to achieve a zero-emission economy by 2050 [6]. Therefore, numerous strategies, regulations, and policies have been implemented to promote decarbonisation, increase energy efficiency, and expedite the adoption of green energy solutions [7]. To achieve net zero, heating systems must shift from fossil fuels to low carbon alternatives like heat pumps, DH, and renewable energy, supported by infrastructure improvements and increased public awareness [8].

In the backdrop of efforts to decarbonise energy sectors in settlements and urban centres, DHS harnessing solar energy as their primary source has emerged as a dominant subgroup within large solar thermal heating systems. As of the close of 2021, a notable 299 large solar DHS, each with individual capacities exceeding 350 kWth and occupying a minimum area of 500 m², collectively boast a substantial capacity of 1645 MWth (equivalent to approximately 2.35 million m²) [9]. Denmark has emerged as a frontrunner in this arena, leading both in the total installed area and the number of installed systems (125 systems), followed by China (41 systems), with increasing interest observed in nations like Germany, Sweden, Austria, Poland, France, Saudi Arabia, and Japan [9]. Documented insights from Plan Energy [10] shed light on Denmark's experiences with DHS utilising solar energy, including solar heating combined with biomass (straw and wood chips) boilers and CHP. The pioneering Danish system in Saltum

dates back to 1988, followed by installations in Rye and Herlev in 1990, and Marstal in 1996, which boasted an impressive 8000 m² of solar collectors, marking it as the world's largest at the time. Over the years, the Marstal facility underwent multiple expansions, eventually reaching 33300 m² in 2018, with the introduction of seasonal thermal energy storage facilitating a high solar fraction.

The Danish DH sector, often regarded as a benchmark, has been subject to numerous studies. Notable among these studies is the work of Čulig-Tokić *et al.* [11], which contrasts DHS in Zagreb and Aalborg, based on data obtained from multiple sources. A survey by Zhang *et al.* [12] conducts a technical evaluation of systems in China and Denmark. Further insights are provided by a study commissioned for DECC [13], which scrutinises four schemes, including Helsinki's renowned DH and cooling network, supplying 90% of the city's heat demand and a portion of its cooling demand. Despite its reliance on natural gas CHP for heating and various cooling technologies, the integration of heat pumps in 2006 marked a significant milestone, covering 4% of the network's total heating energy and 33% of its total cooling. The research extends beyond borders to cover Wandsworth Riverside, London, featuring a hydrothermal energy storage system, Duindorp, the Netherlands, with a low temperature network, and Brook Street, Derbyshire, showcasing a geothermal heat pump and a fitted heat network catering to multiple homes in an area devoid of natural gas.

As per findings from [14], back in 1994, a central heating infrastructure with a supply temperature of 65 °C was established through grassroots efforts in a Danish municipality with 4000 residents. Originally, thermal energy demand stood at approximately 105 kWh/m² per year, but has since decreased to around 60 kWh/m² per year for newly constructed buildings, servicing households, schools, and businesses. Notably, the system boasts a RES share of 56%, with CO₂ emissions of 115 kg/MWh, featuring a robust infrastructure including a 20.1 MW installed capacity, producing 39 GWh per year, and comprising a hot water network spanning 33 km, 67/43°C in summer to 67-80/38-40°C in winter. This integrated solution includes a 5 MW absorption heat pump, a 1 MW electric heat pump, a 13400 m² solar plant, a 3000 m³ heat tank with a capacity of 140 MWh, and a 7.1 MW CHP unit.

Shesho *et al.* [15] presents an optimization model for selecting optimal heating structures in urban settings, considering heat load density, techno-economic factors, and environmental impacts, thereby providing a comprehensive framework for decision-making in the integration of RES into DHS. Rutz *et al.* [16] delves into the analysis of an existing system in Zefenberg, focusing on the incorporation of solar thermal collectors for heating energy production. This DH infrastructure, established in 2006, now integrates RES, including a biogas plant, and underwent further enhancement in 2016 with the addition of a solar plant spanning 8300 m², boasting a peak thermal capacity of 4.6 MW. In [17], the authors evaluate the integration of a central solar heating plant with seasonal storage into the DHS, aiming to reduce costs and CO₂ emissions by utilizing RES and modelling the system as a low temperature DHS based on actual thermal demands.

Data pertaining to DHS utilising solar thermal collectors for heat production in Denmark, including detailed information on production, solar radiation, and efficiency, are accessible via the website [18]. This resource provides hourly, daily, and monthly data for numerous plants in the database. Notably, the system in Jægerspris, established in 2010, spans an area of 13405 m² out of a total area of 31000 m², boasting a maximum thermal power of 9.4 MW and achieving a thermal energy production of 6000 MWh, with a calculated return on investment of 8.3 years.

Numerous comparative studies between district and individual heating systems primarily focus on assessing their cost-effectiveness, technical performance, and environmental impact. The DHS facilitate the containment of CO₂ emissions and pollutants, offering more effective environmental control. Integration into a DHS diversifies heat sources, enhancing system independence and reliability and optimising energy production costs, thereby contributing significantly to environmental preservation and energy conservation. Solar-powered heating systems, when coupled with seasonal storage, enable efficient energy utilisation across seasons, while heat pumps, integrated with CHP, emerge as pivotal in future emissions reduction strategies. The paper's core objective lies in elucidating energy modelling principles, focusing on determining the optimal share of RES within DHS to minimise production costs, utilising the *nPro Energy* software for system simulations. Establishing key indicators is essential for conducting thorough comparisons and drawing conclusive insights. Specifically, the analysis incorporates the calculation of the levelized cost of energy (LCOE), a crucial measure for evaluating economic feasibility.

In this paper, we propose a novel model for the optimal integration of RES into DHS, emphasizing a holistic approach that combines technical, economic, and environmental factors. Unlike previous studies that often focus on isolated aspects, our model incorporates dynamic simulations, real-time data analytics, and advanced optimization algorithms to ensure a comprehensive and adaptive system. This approach not only enhances the efficiency and sustainability of DH but also provides a scalable framework adaptable to various urban settings and climate conditions.

Methods

This paper utilises software analyses to assess heat consumption, encompassing space heating and domestic hot water (DHW) demand, as well as to optimise technology sizing. The selection of an optimal system featuring RES is guided by the LCOE, which enables the comparison of alternative technologies amidst varying demands, investment costs, and heat densities. Leveraging the LCOE as both a technical and economic indicator, the optimal system configuration is defined. Sensitivity analysis is used to identify how much variations in the input values for a given variable impact the results of a mathematical model. Detailed explanations of the software tools utilised are provided below.

Optimisation for district heating systems - nPro Energy

The approach employed for system modelling and optimisation of the energy mix in this study hinges on the utilisation of sophisticated software simulation, *nPro Energy*. This software serves as a robust platform for conducting comprehensive analyses of energy systems and their subsequent optimisation, integrating a multitude of state-of-the-art technologies characterised by intricate mathematical models. These encompass a wide array of energy sources, including those examined in this paper, such as solar hot water collectors, seasonal storage tanks, CHP, heat pumps, and photovoltaic (PV) systems.

The functionality of the *nPro* tool is structured into two principal calculation modules [19, 20]. The first module generates heat and electricity consumption profiles and conducts distribution network calculations, while the second module focuses on technology selection, design optimisation, and system simulation. The energy demand profiles, generated by the first module, serve as the primary link between the two modules and act as the input for the second module. In *nPro*, annual profiles with hourly resolution for space heating and DHW demands

can be created, with heating demand adjusted for weather variations using degree days. The *nPro* stands out for its specialized focus on the calculation and design of heating, cooling, and 5 GDHC/energy networks, leveraging advanced mathematical optimization techniques.

It is noteworthy that *nPro Energy* operates on an hourly time interval, enabling simulation and balancing of complex energy flows within the analysed systems. Moreover, the software facilitates automated visualisation of results, streamlining the interpretation of intricate simulation outcomes.

The LCOE calculation methodology

The LCOE serves as one of the most important indicators for comparing the analysed scenarios internally and against other systems. The formula is utilised to calculate this indicator:

$$LCOE = \frac{C_a}{E} \quad (1)$$

where C_a is the annual costs [EUR per annually], including investment, energy, maintenance, CO₂ emission and additional costs and E – the annual heating energy production [MWh per annually].

Case study overview

Heat load distribution in the district heating system

The DH energy model incorporates climatic data and building typology specific to the city of Ohrid in Republic of North Macedonia. City of Ohrid has with an average annual solar radiation of 2233 hours, features an average temperature of 11.4 °C, with maximums peaking at 34.4 °C in August and minimums plunging to –17.2 °C in January. The DHS is designed to provide heat for space heating and DHW to various public buildings situated in close proximity within a specific area.

Demand profiles are generated in *nPro Energy* with an hourly time-step. In Scenarios 1 and 2, public facilities such as schools, kindergartens, offices, hospitals, a student dormitory, a sports hall, and a swimming pool are considered. These buildings are classified as energy class D, with a specific energy consumption of 110 kWh/m² per year for space heating. Scenario 3 adds 1000 residential buildings to these public facilities to increase linear heat density, with all buildings classified as energy class D and consuming 110 kWh/m² per year. Scenario 4 assesses the same public facilities as in Scenario 1 and Scenario 2, but with improved energy efficiency, classifying the buildings as energy class C with a consumption of 70 kWh/m² per year. Scenario 5 includes 1000 residential buildings along with the public facilities, all classified as energy class C with 70 kWh/m² per year consumption.

Figure 1 illustrates the heating energy consumption of the buildings, indicating the highest consumption during January due to low winter temperatures, while summer months exhibit significantly lower energy consumption for heating DHW. The total annual heat demand by Scenarios are: Scenario 1 and 2 = 7543 MWh, Scenario 3 = 20479 MWh, Scenario 4 = 5578 MWh, and Scenario 5 = 14994 MWh.

System scheme component selection and dimensioning

The system simulation model comprises component mathematical models for heat supply technologies (sources), heat distribution networks and heat consumers – buildings with thermal performances defined according to Scenarios 1-5. Figure 2 illustrates the energy hub system, which includes technologies such as solar thermal energy, thermal storages, natural gas CHP, heat pumps, and a PV plant. These technologies are active in Scenarios 1, 3-5. In contrast,

Scenario 2 is slightly different, as it excludes both the CHP unit and the PV plant. In Scenario 2, the energy demand is met primarily through solar thermal energy, heat pumps, and electricity supplied from the grid. The system is designed to balance energy supply and demand, ensuring reliable provision under various operating conditions.

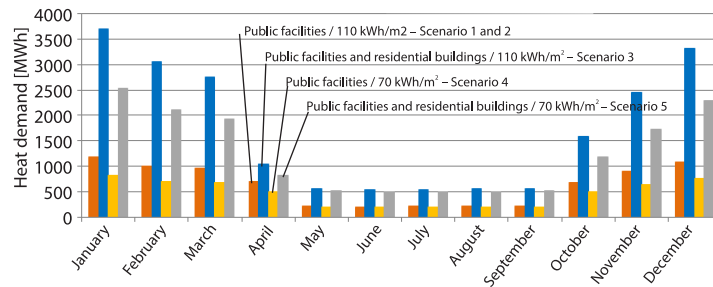

Figure 1. Overview of the heat demand in different scenarios

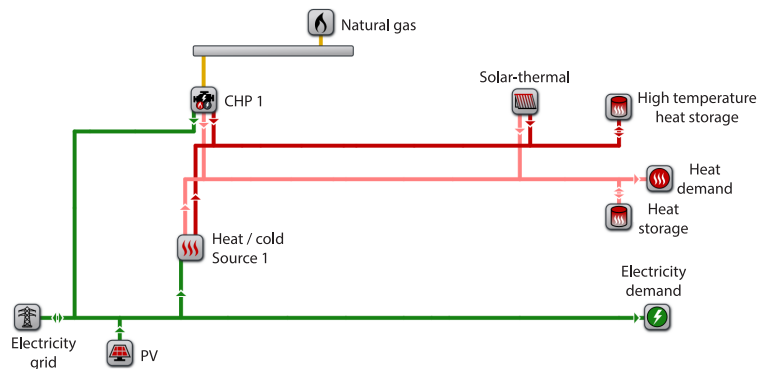

Figure 2. Scheme of the energy hub

The process of sizing these technologies for optimal performance is carried out in the *nPro Energy* software. The criterion used in the optimisation is the minimum production cost LCOE. The input parameters for the energy model, including energy price, investment costs for each large-scale technology, and operation and maintenance (O&M) costs as a percentage of investment, are detailed in tab. 1.

Table 1. Input parameters

Energy price [21]	
Electricity price (supply)	0.12 EUR/kWh
Electricity price (feed-in tariff)	0.06 EUR/kWh
Natural gas price (supply)	0.06 EUR/kWh
CO ₂ price	45 EUR/t
Large-scale technologies	
CHP investment, O&M	1000 EUR/kWeI, 6%/investment
Solar thermal investment, O&M	300 EUR/m ² , 1%/investment
Heat pump water-water investment, O&M	400 EUR/kWth, 1%/investment
Seasonal heat storage investment, O&M	350 EUR/m ³ , 1%/investment
PV plant investment, O&M	700 EUR/kWp, 1%/investment
Piping costs (material, work and installation)	550 EUR/m

The solar thermal system under analysis utilises efficient solar thermal collectors to convert solar energy into heat, aiding in supplying thermal energy to the heating system. To ensure optimal sizing, the collectors are limited to a surface area of less than 10000 m², with an optimal slope set at 25° and an azimuth of 0°. Vacuum collectors, specifically the Vaillant model VTK 570/2, are chosen and the calculations follow the ISO 9806 standard.

The CHP plant generates both electricity and heat, thereby maximising energy efficiency. It holds a crucial role in providing heat energy within the examined hybrid system for central heat supply and DHW. Input data for the analysed systems include 40% electrical efficiency and 50% thermal efficiency.

Incorporating pit thermal energy storage allows the system to store surplus thermal energy generated during periods of high production when the demand is lower. This capability ensures that excess energy produced when supply exceeds demand can be stored for later use. This stored thermal energy can be utilised during periods of high demand or when production from solar collectors is constrained, ensuring a consistent and dependable heat supply. In the analyses presented in this paper, a relative heat loss of 10% over ten days is assumed for the reservoir.

In this study, the water-to-water heat pump efficiently harnesses waste heat energy from Lake Ohrid, utilising measured water temperature data at hourly intervals. The analysis incorporates the efficiency of the Carrier 61 WG heat pump as an input parameter, facilitating precise calculations of the heat pumps' efficiency.

The PV plant harnesses sunlight to produce electricity, serving as a clean and RES that diminishes reliance on conventional power. In this study, the planned installation area for the PV plant is 11.8 m²/kWp, utilising monocrystalline panels with 21% efficiency, positioned with a 25° slope and 0° azimuth (south-facing). Additionally, inverters with 98% efficiency are employed to optimise energy conversion.

The design supply and return water temperatures for the system were set at 70 °C and 50 °C, respectively. According to the DIN13941 standard in the *nPro Energy* software, loss calculations in the distribution network assume a 10% loss in the heat network.

Results and discussion

The diagram presented in fig. 3 is prepared to illustrate the impact of linear heat density on the LCOE, providing valuable insights into the relationship between network density and the production cost of hot water within the system. A dependency curve is constructed for scenarios utilising the same heat sources but varying in heat demand and linear heat density (Scenarios 1 and 3, Scenario 2, and Scenarios 4 and 5). This diagram indicates that increasing network density results in a decrease in LCOE, tab. 2.

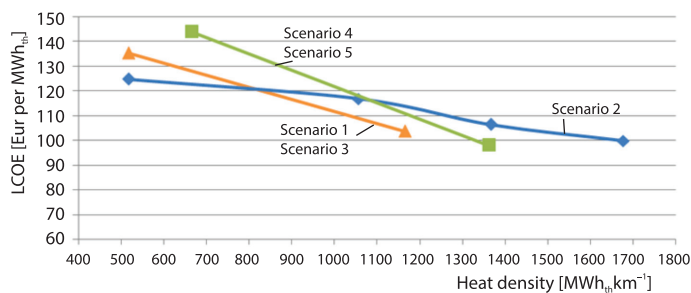

Table 2. The LCOE price by scenario

Scenario	Price	Unit
Scenario 1	135.2	[EUR/MWh]
Scenario 2	124.6	[EUR/MWh]
Scenario 3	103.6	[EUR/MWh]
Scenario 4	143.8	[EUR/MWh]
Scenario 5	97.8	[EUR/MWh]

Figure 3. Impact of the linear heat density on the LCOE

To evaluate how alterations in CAPEX, energy prices, and CO₂ pricing impact the LCOE, a sensitivity analysis was conducted by varying these input parameters. The ensuing diagram, fig. 4, illustrates the results across five scenarios reflecting diverse heat demands, showcasing the fluctuations in LCOE in response to changes in CAPEX, energy costs (natural gas/electricity), and CO₂ emission pricing.

In terms of investment costs, the analysis was made at a change of these costs of $\pm 30\%$ in relation the reference prices shown in the previous chapters. The analysis was made for a change in the price of purchased energy/fuel (electricity and natural gas) of $\pm 20\%$ in relation the reference prices of 120 EUR/MWh for electricity and 60 EUR/MWh for natural gas. The impact of CO₂ price on LCOE is done at CO₂ prices of 0 EUR/t_{CO₂}, 45 EUR/t_{CO₂} (reference price), 60 EUR/t_{CO₂} and 80 EUR/t_{CO₂}.

As for the impact of investment costs on LCOE, it is the largest in Scenario 4, but it is also significant in Scenario 1 and Scenario 5. This shows that as the demand for heating energy decreases, the impact of investment costs on LCOE becomes more pronounced; that is, at lower network density, the effect is more significant.

The energy cost has the greatest impact on LCOE in Scenario 3 and Scenario 2. In Scenario 2, the large impact is due to the absence of a natural gas cogeneration unit and a PV plant, *i.e.* own electricity production. The high impact on the LCOE in Scenario 3 results from the high energy consumption. The incorporation of electricity generation technologies directly correlates with the minimal impact of energy prices on LCOE, as a significant portion of electricity demand is met through self-generation in the other scenarios. This illustrates how reduced dependence on external energy sources can help stabilise LCOE fluctuations in the analysed energy system.

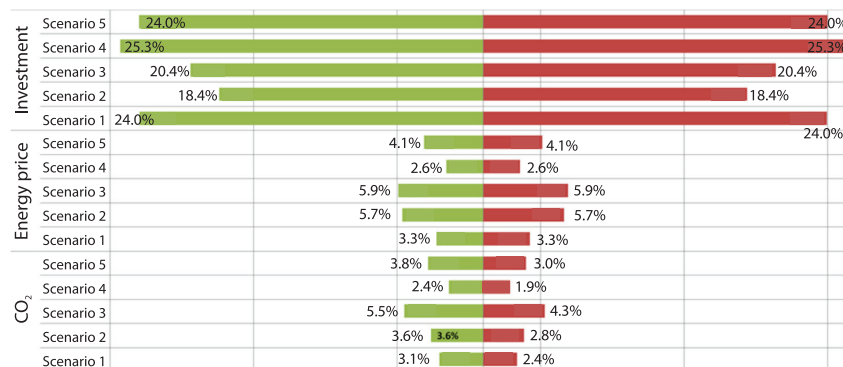

Figure 4. Sensitivity analysis

According to the diagrams shown, the Scenario 4, which consists of a cogeneration plant, a heat pump, solar thermal collectors, a seasonal heat storage tank and a PV plant, the change in the price of CO₂ has the least impact on the LCOE compared to the other four scenarios. This is a result of the lowest CO₂ emission, which in turn is a result of the fact that the entire amount of electricity is produced in a PV plant and a cogeneration plant (which is not the case in Scenario 2), and the share of the cogeneration plant in the energy mix is the smallest compared to Scenarios 1, 3, and 5. This indicates that reliance on RES provides favourable results for both LCOE value and environmental protection. The Scenario 3 has the greatest impact, as the scenario with the highest heat energy demand and the highest network density, with the highest CO₂ emissions.

Conclusions

This research assesses the techno-economic viability of DHS investments by determining the cost-effectiveness threshold. By developing and analyzing five simulation models for existing buildings in a designated area of Ohrid, the study focuses on their energy consumption patterns. The results offer a detailed understanding of the conditions under which DHS become financially viable, providing a basis for enhancing energy efficiency and sustainability in urban environments.

In conclusion, this scientific paper delves into a comprehensive analysis of thermal energy costs, primarily assessed through the LCOE. The analyses have introduced indicators that elucidate the influence of grid density, heat consumption, investment, energy price, and CO₂ pricing on LCOE. Among the scenarios, Scenario 5 emerges as the most cost-effective for a DHS, boasting a low LCOE of 98 EUR/MWh, coupled with a linear heat density of 1363 MWh/km and a heat demand of approximately 15 GWh per year. In summary, the DHS proves to be both cost-effective and energy-efficient, providing independence from fuel imports and aiding in achieving CO₂ targets. Its flexibility, stability, and cost-effectiveness make it an optimal solution for heating needs, particularly due to the potential for diversified heat sources, resulting in an optimised supply.

Nomenclature

C_a – annual costs, including investment, energy, maintenance, CO₂ emission and additional costs, [EUR per annually]
CAPEX – investment cost, [EUR]
 E – annual heating energy production, [MWh/a]
LCOE – levelized cost of energy, [EUR/MWh]

O&M – operation and maintenance cost, [%/investment]

Acronyms

CHP – combined heat and power
DHS – district heating systems
DHW – domestic hot water

References

- [1] ***, World Energy Outlook 2023, IEA, <https://www.iea.org/reports/world-energy-outlook-2023>, 2023
- [2] ***, District Heating, IEA, <https://www.iea.org/reports/district-heating>,
- [3] ***, Tracking Clean Energy Progress 2023, IEA, <https://www.iea.org/reports/tracking-clean-energy-progress2023>, 2023
- [4] ***, DHC Market Outlook 2023 Insights & Trends, Euro Heat and Power, https://api.euroheat.org/uploads/DHC_Market_Outlook_Insights_Trends_2023_81498577a7.pdf, 2023
- [5] ***, Global heat pump sales continue double-digit growth, IEA, <https://www.iea.org/commentaries/global-heat-pump-sales-continue-double-digit-growth>
- [6] ***, 2050 Long Term Strategy, European Commission, https://climate.ec.europa.eu/eu-action/climate-strategies-targets/2050-long-term-strategy_en
- [7] ***, On the Path to Net Zero: low carbon heating, Energy Saving Trust, <https://energysavingtrust.org.uk/path-net-zero-low-carbon-heating/>
- [8] ***, European Council meeting – Conclusions, <https://www.consilium.europa.eu/media/41768/12-euco-final-conclusions-en.pdf>
- [9] ***, Solar Heat Worldwide, 2022, Global Market Development and Trends in 2021 / Detailed Market Figures 202, IEA, <https://www.iea-shc.org/Data/Sites/1/publications/Solar-Heat-Worldwide-2022.pdf>, 2022
- [10] ***, Solar District Heating, Inspiration and Experiences from Denmark, Danish District Heating Association, PlanEnergi, <https://task55.iea-shc.org/Data/Sites/1/publications/SDH%20Inspiration%20Experience%20DK%20v5.pdf>
- [11] Čulig-Tokić, D., *et al.*, Comparative Analysis of the District Heating Systems of Two Towns in Croatia and Denmark, *Energy*, 92 (2015), Dec., pp. 435-443
- [12] Zhang, L., *et al.*, Comparison of District Heating Systems Used in China and Denmark, *International Journal of Sustainable and Green Energy*, 4 (2015), 3, pp. 102-116
- [13] Foster, S., *et al.*, Heat Pumps in District Heating, URN 15D/537, Element Energy and Carbon Alternatives, Dep. of Ene. and Climate Chan., London, UK, 2016

- [14] Galindo Fernandez, M., et al., *Integrating Renewable and Waste Heat and Cold Sources into District Heating and Cooling Systems*, JRC123771, Publications Office of the European Union, Luxembourg, Luxembourg, 2021
- [15] Shesho, I., et al., Techno-Economic and Environmental Optimization of Heat Supply Systems in Urban Areas, *Thermal Science*, 22 (2018), S5, pp. S1635-S1647
- [16] Rutz, D., et al., *Upgrading the Performance of District Heating Networks*, 978-3-936338-49-2, WIP Renewable Energies, Munich, Germany, 2018
- [17] Andreau Javier, F., et al., Evaluation of Integration of Solar Energy into the District Heating System of the City of Velika Gorica, *Thermal Science*, 20 (2016), 4, pp. 1049-1060
- [18] ***, Solar Heat Data, <https://solarheatdata.eu/>
- [19] Wirtz, M., 2023, nPro: A Web-Based Planning Tool for Designing District Energy Systems and Thermal Networks, *Energy*, 268 (2023), 126575
- [20] ***, nPRO, <https://www.npro.energy/main/en/help/all-tool-features>
- [21] ***, HUDEX, <https://hudex.hu/en/>