

OPTIMIZATION AND EXPERIMENTAL VALIDATION OF A NATURAL CONVECTION SPACE HEATER USING THE PELTIER ELEMENTS

by

**Milan B. PUPČEVIĆ^a, Petar GVERO^a, Čedomir ZELJKOVIĆ^b,
Milovan KOTUR^a, Predrag MRŠIĆ^b, and Saša TEŠIĆ^a**

^aFaculty of Mechanical Engineering, University of Banja Luka, Banja Luka, Bosnia and Herzegovina

^bFaculty of Electrical Engineering, University of Banja Luka, Banja Luka, Bosnia and Herzegovina

Original scientific paper
<https://doi.org/10.2298/TSCI230404256P>

In this paper an experimental analysis was done aiming at studying the possibility of applying Peltier thermoelectric modules for building heating, more precisely, the optimization of a heat exchanger was performed. The concept of the system was designed to work without freon and harmful impact on the environment. The paper aims to develop a detailed mathematical optimization model of the existing heat exchanger for space heating by natural convection. Based on the optimal model, the new aluminum heat exchanger was created. The experiment was designed so that the Peltier elements were positioned on the heat exchangers and the input current and temperatures were measured. Firstly, experimental measurements were performed for the existing commercial heat exchanger, and, then, measurements were repeated with a new optimal heat exchanger under the same conditions. The COP of a space heating system using a Peltier thermoelectric generator has a low value if the system operates with natural convection and heat exchangers without optimal fin spacing. Optimizing the distance between the fins on the heat exchanger provides an increase in heat flow by convection almost up to ten times and the COP increases more than three times. This work has mathematically and experimentally confirmed that there is optimal fin spacing for finned heat exchangers with natural convection.

Key words: *heat exchanger, heating, thermoelectric effect, peltier module*

Introduction

It is known that thermoelectric elements have initially found their application in the space program, but subsequently also in the production of portable car freezers, for cooling computers, in the automotive industry, as well as in the industry utilizing waste heat at high temperatures [1-3]. Decreasing prices of the individual components, as well as entire thermoelectric modules (TEM), in the last decade have led to the idea that they can also be used in HVAC systems without refrigerants [4, 5]. These systems are interesting if supplied by the

^{*}Corresponding author, e-mail: milan.pupcevic@mf.unibl.org

electricity from PV modules [6], because solar cooling does not still have an adequate commercial solution. As refrigerants used in conventional air conditioners are freons, this leads to irreversible damage to the ozone sphere. The additional environmental problem is the greenhouse effect as a result of burning fossil fuels used for generation of electricity used in HVAC systems. This continuous increase of global warming indirectly leads to a higher demand for air conditioning systems with freon.

The position of these devices in the building itself is not limited due to their small dimensions, thus they can be installed in the wall [7], as shown in fig. 1, or in the ceiling of the heated room [8, 9].

There is also a possibility to design an air channel in which the heat exchanger with a Peltier element as a heat generator could be placed, whereby air circulation from the space would be provided through the module [10]. During the construction of new buildings the heat source can be easily positioned in the wall or in the ceiling. However, in existing buildings it is very difficult to reconstruct the ceiling and it would be financially unjustified. The idea of the work is to position the installation aforementioned on the existing wall, with additional installation of an isolation panel that separates the system from the surrounding air. The said external, vertical wall can be made of PV panels. The width of the channel in the wall intended for the circulation of outside air is equal to the width of the heat exchanger.

The heating system with natural convection positioned on the ceiling of the room shown in fig. 2 has other disadvantages. Warmer air is retained in the upper part of the space, which causes discomfort to the users while staying there and a feeling of coldness. It is possible to maintain a constant operating temperature of thermocouples with a small deviation of ± 0.1 °C [11]. The TEM mostly have constant voltage and temperature values at certain temperature differences.

Even though a large number of papers have analyzed the efficiency of the Peltier as an independent component [12-15], for a specific application of the TEM in HVAC systems, it is necessary to have more detailed results of the complete system with heat exchangers. Contrary to some authors [16-18] who considered entire systems with TEM the goal of this paper is to create a mathematical model and, then, to experimentally confirm the results obtained with the mathematical model on a smaller scale.

In an earlier paper [19], it was concluded that the system with Peltier elements and aluminum heat exchangers with natural convection is usable. The system easily reaches 90 °C

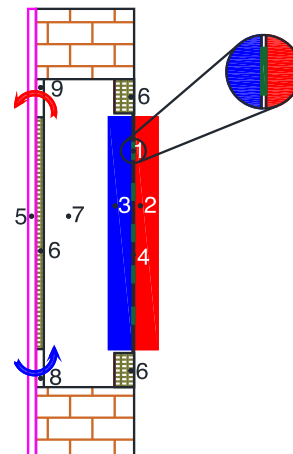

Figure 1. Heating system with TEM positioned in the wall; 1 – thermoelectric module, 2 – heat sink-hot side, 3 – heat sink-cold side, 4 – module carrier-plexiglas, 5 – PV module, 6 – insulation, 7 – air duct, 8 – air inlet, and 9 – air outlet

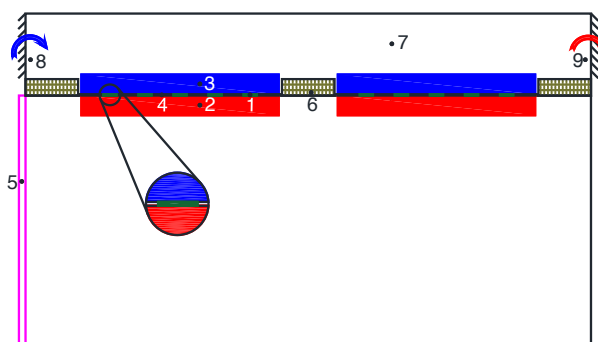

Figure 2. Heating system with TEM positioned in the ceiling; 1 – thermoelectric module, 2 – heat sink-hot side, 3 – heat sink-cold side, 4 – module carrier-plexiglas, 5 – PV module, 6 – insulation, 7 – air duct, 8 – air inlet, and 9 – air outlet

at low voltages and currents, which can also be provided by solar PV systems. A disadvantage of such a system is the low heating COP.

The goal of this paper is to create a detailed mathematical model of heat transfer by natural convection and then to optimize the distance between fins on the exchanger. According to the optimal mathematical model defined for the heat exchanger with fins, a new heat exchanger was made and identical measurements were repeated. If the mathematical model of the new heat exchanger is confirmed experimentally, the idea is to show optimal heat exchangers for several different dimensions of heating bodies. For optimal heat exchangers defined in this way, completely covered with Peltier elements, heat flow emitted to the air in the room can be defined.

Methodology

Analytical analysis of the natural convection heat exchanger

Heat transfer is very specific in heat exchangers with narrow fins measuring around 1 mm. Natural convection from a vertical finned surface with rectangular shape has been the subject of numerous studies, mostly experimental. Bar-Cohen and Rohsenow [20] have compiled the available data under various boundary conditions and developed correlations for the Nusselt number and optimum spacing.

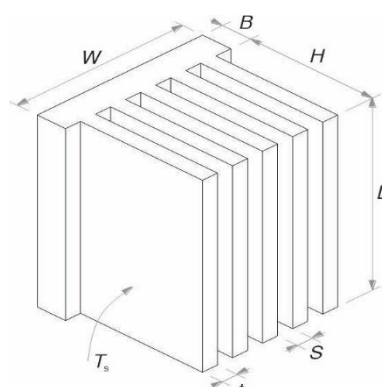

Figure 3. Dimensions of a finned surface oriented vertically

Heat exchanger dimensions that were used in the experiment were 40×40 mm, which was a starting value for the mathematical model, and a limit value of square exchanger dimensions to be used in the space is 1×1 m. As shown in fig. 3, characteristic length of a heat exchanger include the height $L = 40$ mm, heat exchanger width is $W = 40$ mm, and height from the base $H = 25.1$ mm. The fin spacing was $S = 1.5$ mm and fin thickness $t = 1.2$ mm. In order to define the heat exchanger surface A_s , the number of fins $n = 15$ is deemed necessary. The calculation was first performed for the existing heat exchanger and the resulting values were analyzed with the values obtained experimentally.

The heat exchanger model used during the experimental analysis had a very small fin spacing S , and therefore did not have optimum fin spacing for the given dimensions.

The surface temperature T_s of 90 °C was adopted as in the experiment, and the ambient temperature T_∞ at a value of 20 °C. The average temperature T_f for which the fluid characteristics were adopted was 55 °C. The characteristic length for vertical parallel plates used as fins is usually taken to be the spacing between adjacent fins S , where the Rayleigh number is expressed according to eq. (1), where β is the volume expansivity, ν the kinematic viscosity, and Pr the Prandtl number:

$$Ra_s = \frac{g\beta(T_s - T_\infty)S^3}{\nu^2} Pr \quad (1)$$

The fin height L could also be used for characteristic length, where the ratio of these two Rayleigh numbers is defined by:

$$Ra_L = Ra_s \frac{L^3}{S^3} \quad (2)$$

During the experimental analysis, it was observed that the temperature distribution along the length of the exchanger was uniform, that is, it had very small deviations [19]. With that assumption, the recommended relation for the average Nusselt number for vertical isothermal parallel plates [21, 22] was adopted, that is $T_s = \text{constant}$:

$$\text{Nu} = \left[\frac{576}{\left(\frac{\text{Ra}_s S}{L}\right)^2} + \frac{2.873}{\left(\frac{\text{Ra}_s S}{L}\right)^{0.5}} \right]^{-0.5} \quad (3)$$

A fin spacing problem will be shown, where the convection heat transfer coefficient according to eq. (4) has a small value for the specified real exchanger with the Rayleigh and Nusselt number defined:

$$\alpha = \frac{\lambda}{S} \text{Nu} \quad (4)$$

which implies a very small heat transfer rate, defined by:

$$Q_{\text{con}} = \alpha A_s (T_s - T_\infty) = \alpha (n2LH)(T_s - T_\infty) \quad (5)$$

This shortcoming is due to narrow fin spacing and the impossibility of ideal air-flow between two fins, and, therefore, optimum heat transfer. To overcome this shortcoming, a further mathematical model was defined with optimum fin spacing, because there must be a distance that ensures the maximum heat flow by natural convection from the exchanger [20, 21]:

$$S_{\text{opt}} = 2.714 \left(\frac{S^3 L}{\text{Ra}_s} \right)^{0.25} = 2.714 \frac{L}{\text{Ra}_L^{0.25}} \quad (6)$$

which leads to the conclusion that the Nusselt number for $S = S_{\text{opt}}$ must be a constant value:

$$\text{Nu} = \frac{\alpha S_{\text{opt}}}{\lambda} = 1.307 \quad (7)$$

According to eq. (6), for a commercial heat exchanger as shown in the model from fig. 4(a) that has the distance between the fins $S = 1.5$ mm and the length of the fins $L = 40$ mm, the optimal distance between the fins is $S_{\text{opt}} = 4.71$ mm. Furthermore, a detailed structural analysis was performed for the production of the exchanger so that the fin thickness dimensions and the exchanger width were kept.

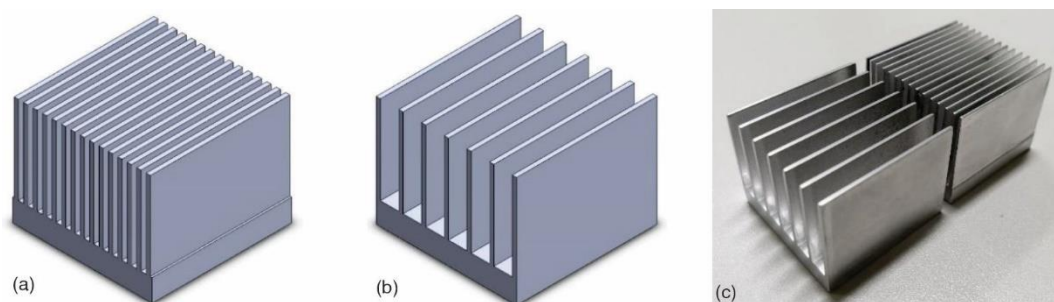

Figure 4. Heat exchangers for the heating system; (a) a heat exchanger model with non-optimal fin spacing; (b) a heat exchanger model with optimal fin spacing, and (c) a comparison of heat exchangers made with and without optimal fin spacing

In addition to convection, heat transfer must also include radiation if a complete and detailed mathematical model is desired, which is done according to eq. (8), where ε is the emissivity of the surface and $\sigma = 5.67 \cdot 10^{-8}$ [Wm²K⁴] is the Stefan-Boltzmann constant. Heat transfer radiation obtained from a heat exchanger with a constant surface temperature T_s can be divided into radiation from exposed surfaces and radiation in the channel [23]:

$$Q_{\text{rad}} = [\varepsilon_{\text{ch}}SL + \varepsilon(A_s - A_{\text{ch}})]\sigma(T_s^4 - T_{\infty}^4) \quad (8)$$

Channel radiation has an effective channel emittance ε_{ch} [24], unlike exposed surfaces that have an emissivity ε :

$$Q_{\text{r, ch}} = \varepsilon_{\text{ch}}SL\sigma(T_s^4 - T_{\infty}^4) \quad (9)$$

Some authors [24, 25] ignore small surfaces and introduce certain simplifications for surfaces that do not emit much energy by radiation. Equation (8) is written taking into account all surfaces of the heat exchanger according to fig. 3:

$$Q_{\text{rad}} = (n-1)Q_{\text{r, ch}} + [2LH + nt(L + 2H) + 2B(L + W)]\varepsilon\sigma(T_s^4 - T_{\infty}^4) \quad (10)$$

Based on the total heat flow from the exchanger, a number of possibilities were analyzed and it was observed that the exchanger would give its maximum thermal energy for the number of fins $n = 7$ and the distance $S_{\text{opt}} = 5.26$ mm, fig. 5. If an exchanger with $S = 4.71$ mm and $n = 7$ is modeled, heat flow by convection is 8.815 W, while an exchanger with 7 fins and fin spacing of 5.26 mm shown in fig. 4(b) emits 9.477 W by convection.

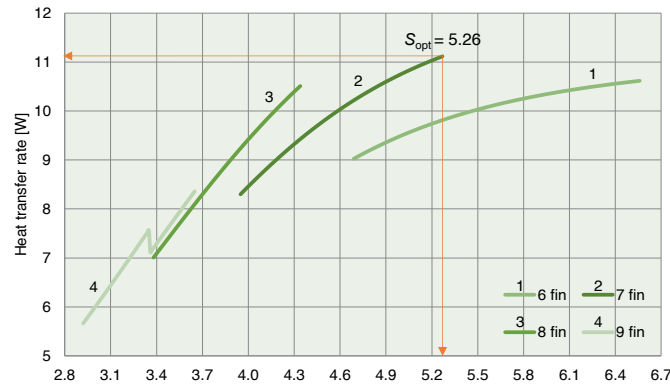

Figure 5. Optimum fin spacing for a 40×40 mm heat exchanger

Channel radiation on the heat exchanger can also be defined by the body view factor \hat{F}_{ch} [24]:

$$\hat{F}_{\text{ch}} = \frac{1}{\frac{1-\varepsilon}{\varepsilon} + \frac{1}{F_{S-\infty}}} \quad (11)$$

where $F_{S-\infty}$ is the total factor between the walls and base of the duct and the surrounding air.

If the shape factor is included in the equation for the amount of energy obtained by channel radiation, and if the channel height H is not ignored when defining the surface, as in eq. (9), a new equation is obtained as:

$$Q_{r, ch} = \frac{(S + 2H)L\sigma(T_s^4 - T_\infty^4)}{\frac{1 - \varepsilon}{\varepsilon} + \frac{1}{F_{S-\infty}}} \quad (12)$$

The total factor $F_{S-\infty}$, for the channel shown in fig. 6, has a very demanding definition procedure, and it depends on the shape of the channel on the exchanger and fins. For an exchanger with fins of constant thickness, according to [24], the view factor can be defined according to:

$$F_{S-\infty} = 1 - \frac{2\bar{H} \left[(1 + \bar{L}^2)^{1/2} - 1 \right]}{2\bar{H}\bar{L} + (1 + \bar{L}^2)^{1/2} - 1} \quad (13)$$

The view factor shown by eq. (13) is not directly defined by the length of the fin or channel L and the height of the fin or channel H , but rather by their relationship with the width of the channel S :

$$\bar{L} = \frac{L}{S}, \quad \bar{H} = \frac{H}{S} \quad (14)$$

Figure 7 shows the heat flow values for different dimensions of a commercial heat exchanger, which were confirmed experimentally for a 40×40 mm heat exchanger, and, then, modeling was performed for several standard dimensions of heating bodies (Q_{rad} – radiation, Q_{con} – convection, and Q – total). Based on the presented mathematical model, the heat flow values for the heat exchanger with optimal distance between the fins are shown ($Q_{rad, opt}$ – radiation, $Q_{con, opt}$ – convection and Q_{opt} – total). The amount of heat received by radiation has approximate values for these two cases and the curves in the diagram almost match.

It was observed that the optimal distance between the fins led to an increase in heat transfer by convection

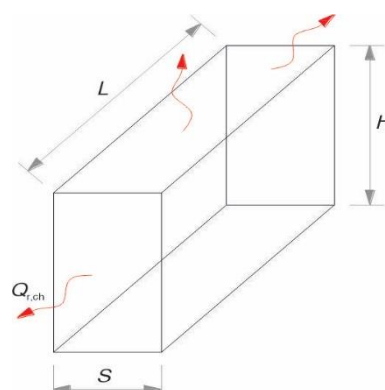

Figure 6. A heat exchanger channel

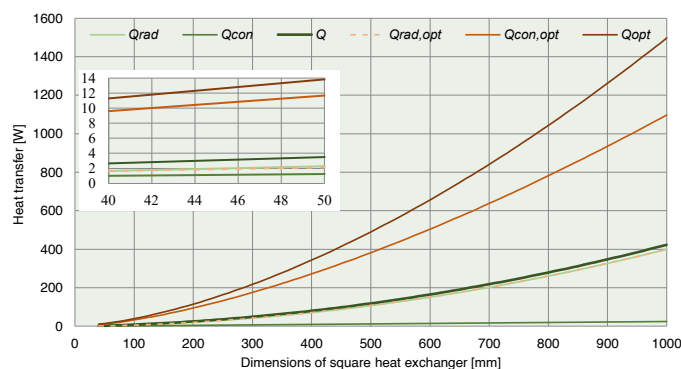

Figure 7. Heat transfer for different heat exchanger dimensions at 90 °C

from $Q_{\text{con}} = 1.026$ W, to $Q_{\text{con,opt}} = 9.477$ W, whereby heat flow was almost ten times higher. The number of fins was reduced from 15 to $n = 7$. The convection heat transfer coefficient in that case increased from 0.451 to $\alpha = 8.671$ [Wm^2K^{-1}].

The amount of heat obtained by radiation from the non-optimal heat exchanger was 1.664 W, which generated total heat from the non-optimal heat exchanger in the amount of 2.69 W. If the input electrical power (9,026 W) and the amount of heat obtained are considered, the heating coefficient of performance is obtained in the maximum amount:

$$\text{COP} = \frac{Q}{P} = 0.298 \quad (15)$$

It was observed that the COP had a very small value because the heat exchanger that did not have optimal fin spacing and was not able to deliver the maximum amount of heat for that surface of the Peltier element. By optimizing the heat exchanger with natural convection, the COP increased from 0.298 to a value greater than 1 (COP was in the range from 0.74 to 1.12 at input electrical power in the range from 15 W to 9.9 W), with the total heat flow from the new heating element being 11.1 W (heat obtained by convection 9.477 W and radiation 1.623 W). In addition, a system was considered in which the Peltier element and the heat exchanger are of the same surface, which is not rational. It is necessary to reduce the number of TEMs and therefore the input electric power, and to increase the area of the exchanger, that is, to optimize the number of modules on the exchanger of a certain area.

The experimental set-up

Based on the analysis of previous research [6, 26, 27], an installation, shown in fig. 8, was designed so that one side of the Peltier element was maintained at a constant temperature using a laboratory cooling device. The accuracy of air temperature adjustment inside the cooling device was ± 0.1 °C, which simulated the environment temperature. The temperature of adjacent rooms, that is the air temperature in the laboratory where the installation was located, was maintained at a fixed desired temperature of 20 ± 0.5 °C using a heat pump.

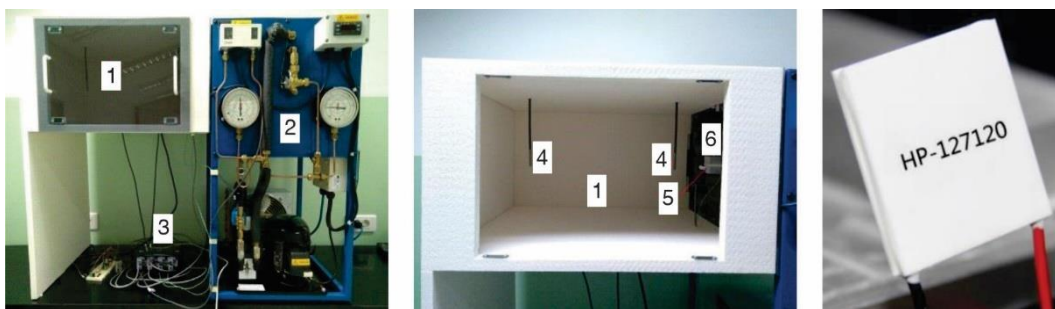

Figure 8. Experimental installation for the TEM analysis and Peltier module:

1 – experimental room/heated room, 2 – cooling device that simulates outside air, 3 – data acquisition, 4 – air temperature sensors in the room, 5 – heat exchanger surface temperature sensors, and 6 – heat exchanger on the warm side

The basic component of the installation with a thermoelectric generator (TEG) is certainly a Peltier element shown in fig. 8. The contact of a thermomodule with the heat exchanger was made using thermal paste. The existing heat exchangers were identical on both sides and made of aluminium alloy, as shown in fig. 4(c). The space between hot and cold air is separated by 4 mm thick plexiglass. It played the role of a thermomodule support along with the rest of

the installation. The electrical cables that supply the Peltier element were located in Plexiglass and had no effect on air-flow through the heat exchangers.

The warm (winter) or cold (summer) side of a Peltier element had variable temperatures depending on the demands, and the heat exchanger was mounted on the device itself in order to increase the surface area for transferring heat to the ambient air. The thermomodule was powered by a 24 V power supply with the ability to regulate voltage from 0-14.5 V and current from 0-12 A. Temperature sensors were PT100 probes, with a resolution of ± 0.1 °C. The acquisition to which the sensors were connected was manufactured by *QuantumX*, a *MX840B* model. The acquisition was moderated with calibrated devices and measured voltage and current at the ends of the Peltier element and temperature at several points.

Results and discussion

The results of experimental measurements are presented simultaneously for the non-optimal and optimal heat exchanger. The analysis of rapid heating of the heat exchanger aims to achieve the desired temperature in a short period of time, and the results are shown in fig. 9. Certainly, this is very important when starting the system after an interruption in operation, and it has been observed that the exchanger has reached a temperature of 90 °C in less than 4 minutes. The external air temperature during the measurement shown in fig. 9. was within 10 ± 0.5 °C.

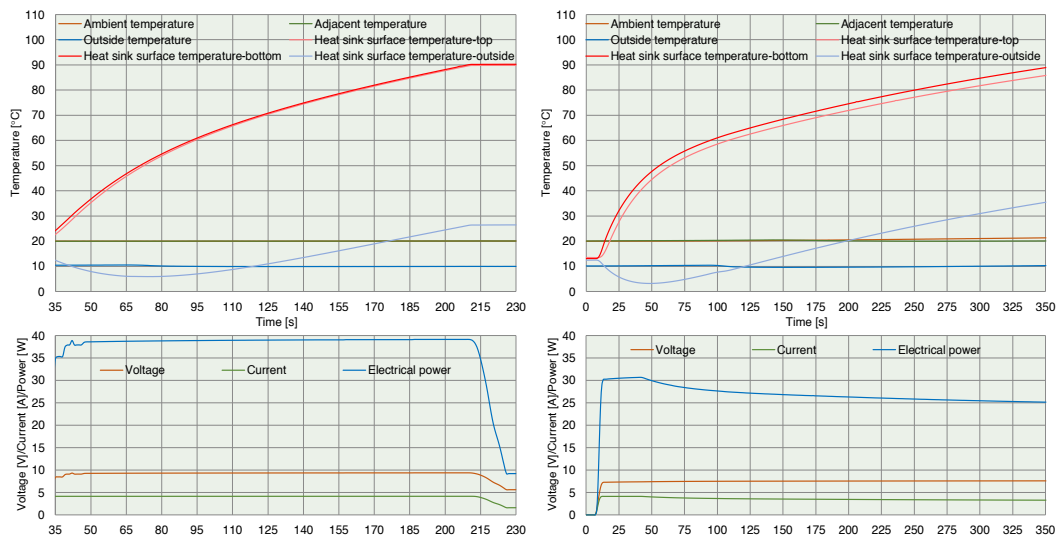

Figure 9. Experimental results of measurements of rapid heating of the aluminium heat exchanger; (a) a heat exchanger with non-optimal fin spacing and (b) a heat exchanger with optimal fin spacing

Figure 10 shows the results of gradual heating of the heat exchanger in order to analyze the stability of the system. More precisely, the goal of that measurement has been to achieve the desired temperature on the heat exchanger with minimal energy consumption and to reach a conclusion as to whether the system can work stably with parameters changed.

Figure 11 shows the measurement results for the heat exchanger with a Peltier thermoelectric element as a heat generator and regulation system. The regulation system has had a heat exchanger temperature set at 90 °C. The goal is to analyze the behavior of the heating sy-

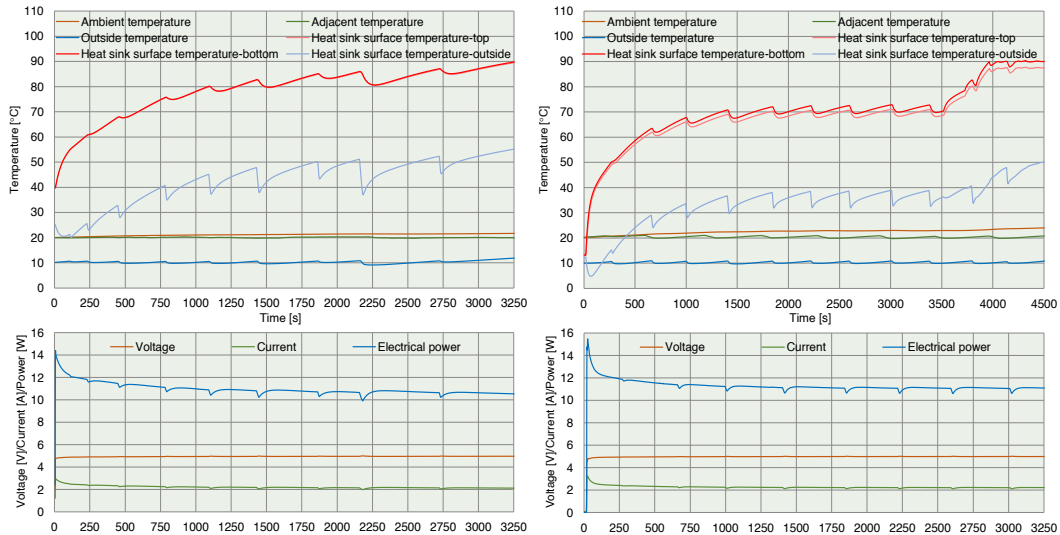

Figure 10. Experimental results of measuring gradual heating of the heat exchanger; (a) a heat exchanger with non-optimal fin spacing and (b) a heat exchanger with optimal fin spacing

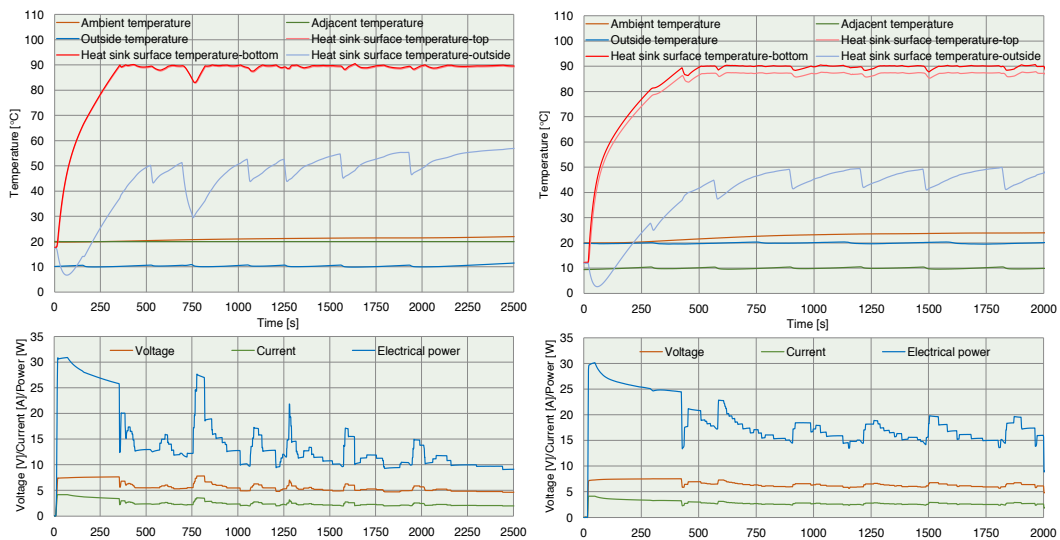

Figure 11. Experimental results of measuring regulated heating of the heat exchanger; (a) a heat exchanger with non optimal fin spacing and (b) a heat exchanger with optimal fin spacing

stem. It has been observed that the heat exchanger has had a very rapid temperature drop with the change in the outside air temperature. With the change of outside air temperature from 10.9 °C to 10.0 °C (time 745 seconds in the diagram), the temperature of the heat exchanger in fig. 11(a) in heated room has dropped from the set value to 82.8 °C in a time period of 60 seconds. For the same condition, the heat exchanger in contact with the outside air had a

temperature change from 51.2-29.5 °C. The regulation system increased the electrical power from 11.9-27.6 W to ensure the set temperature of the heating body. Electricity consumption is low during this temperature change because the regulation system works with increased electrical power for a very short time. The heating system operates within 3 minutes with the electrical power of 12 W, and already in an additional minute the electrical power is 9.9 W.

The experiment started at a room temperature of 20.0 °C, and during the measurement for the non-optimal heat exchanger it reached 22.7 °C. The temperature of the exchanger in the environment has initially cooled below the air temperature and then heated up to a maximum temperature of 56.4 °C. The temperature difference between the heat exchangers on the hot and cold sides has been 31.4 °C on average, while the minimum and maximum temperature differences have been 0.1 °C and 47.8 °C, respectively. For the heat exchanger with optimal fin spacing, the experiment started at a temperature of 20.0 °C, and it reached the maximum air temperature of 24.7 °C in the experimental room.

Figure 12 shows heat transfer for the temperatures obtained by experimental measurement from fig. 11. Figure 12(a) shows a comparison of experimentally obtained data for the heat exchanger with non-optimal fin spacing (experimental non-optimal) and heat transfer data based on an analytical model (analytical non-optimal). Based on the experimentally obtained temperatures, analytical heat transfer data for the optimal (analytical-optimal) and non-optimal (analytical-non-optimal) heat exchanger are shown. Figure 12(b) shows data for the experimental measurement on the heat exchanger made according to the optimal fin spacing (experimental-optimal). The data defined as experimental have been calculated using the heat loss in the experimental room. Deviations between the experiment and the analysis at the beginning of measurements shown in fig. 12(b) are due to sudden heating of the heat exchanger and gradual heating of the air in the room. More precisely, at the beginning of the measurement, the air inside the experimental room and adjacent rooms has been at the same temperature, with small values of the convection heat transfer coefficient. These coefficients inside and outside all structures have been recalculated for each temperature sample, that is, once a second, whereby with an increase in the ambient air temperature, a realistic picture between the the comparison of analysis and experiment has been obtained.

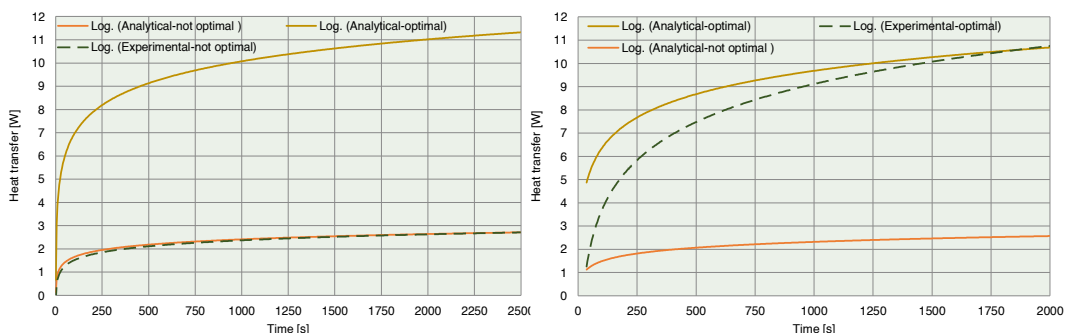

Figure 12. The comparison of analytical and experimental results of measurements shown in fig. 9; (a) a heat exchanger with non-optimal fin spacing and (b) a heat exchanger with optimal fin spacing

Conclusions

This paper presents an experimental analysis for the justification of using a space heating system based on the Peltier TEG. For this purpose, the measurement and simulation of

the heat generator have been carried out. This generator could be positioned inside the wall of the building, with solar PV panels as a source of electricity. Measurement acquisition has collected data on input voltage, input current, internal and external air temperatures, and surface temperatures of the heat exchanger on the hot and cold side. Aluminium heat exchangers have been used, which make up the heating body together with the Peltier element.

On the TEM with the heat exchanger with non-optimal fin spacing, the maximum surface temperature of 90 °C was reached, at the input electric power of 9.026 W and the outside air temperature of 10 °C. Given that the system delivered only 2.69 W of heat energy into the space, it can be concluded that the COP is small (0.298). Based on the experimental measurements, it can be concluded that the system works stably, because it manages to heat the room air to a temperature of 22.7 °C.

Considering the value of input electricity, the value of heat released into the space is very small, which leads to the conclusion that, without optimizing the heat exchanger, this system is not justified to use. In the paper, the optimization of the heat exchanger with parallel fins was carried out, that is, the optimal distance between fins or the width of channels. A detailed mathematical model of heat transfer with natural convection has been created, and, then, a new heat exchanger has been made according to the defined model. With the new heat exchanger with optimum fin spacing, identical measurements were repeated as in the first case. In order to perform a comparative analysis of these two exchangers, the same exchanger on the cold side was kept, as well as the fluid parameters.

The optimal heat exchanger for natural air circulation, heated up to 90 °C, provides heat flow to the space in the amount of 11.1 W, but not at the same current characteristic as the non-optimal exchanger. In order to maintain the same temperatures as in the first case, the system ensures much more heat in the room, but also consumes more electricity. For the obtained quantities of heat flow and consumed electrical energy in the system, it can be concluded that the COP is within the limits of 0.6-1.2. When heating up the heat exchanger and ambient air to the set temperature, the COP has ranged between 0.6-0.9. When the desired temperature has been reached and the system has had stable electricity consumption, the COP has ranged between 0.9-1.1. The maximum recorded value of COP during a series of measurements has been 1.9, but only for a short time. A system with these COP values is not competitive with heat pumps, but it is certainly one of the options for replacing freon systems.

Using a system with forced air circulation would further increase the efficiency of the system. In addition to defining the system for air cooling, further research should aim to optimize the number of modules per surface of the exchanger, that is, the arrangement of a smaller number of modules on a larger surface of the exchanger, and thus an increase in COP.

Acknowledgment

The authors acknowledge the support of the European Research Executive Agency (REA) for funding this research under the project “ENPOWER – Enhancing Scientific Capacity for Energy Poverty (101160253 — ENPOWER — HORIZON-WIDERA-2023-ACCESS-02)”.

Disclaimer

Funded by the EU. Views and opinions expressed are however those of the author(s) only and do not necessarily reflect those of the EU or European Research Executive Agency (REA). Neither the EU nor the granting authority can be held responsible for them.

Nomenclature

A_{ch}	– surface area of heat exchanger channel, [m ²]
A_s	– total surface area of heat exchanger, [m ²]
B	– base thickness of heat exchanger, [mm]
\hat{F}_{ch}	– body shape factor, [–]
$F_{S-\infty}$	– total view factor between the walls and the base of the channel and its surrounding, [–]
g	– gravitational acceleration, [ms ⁻²]
H	– channel or fin height, [m]
\bar{H}	– normalized channel or fin height (H/S), [–]
I	– current, [A]
L	– length of fin heat exchanger, [m]
\bar{L}	– normalized channel or fin length, (L/S) [–]
Nu	– Nusselt number, [–]
n	– number of fins, [–]
n_{opt}	– optimum fin number, [–]
P	– electric power, [W]
Pr	– Prandtl number
Q	– total heat transfer rate, [W]
Q_{con}	– total convection heat transfer rate, [W]
Q_{rad}	– total radiation heat transfer rate, [W]
Ra_L	– Rayleigh number (characteristic length L)
Ra_S	– Rayleigh number (characteristic length S)

S	– fin spacing, [mm]
S_{opt}	– optimum fin spacing, [mm]
T_{adj}	– temperature of adjacent space, [K]
T_f	– film temperature $(T_s + T_\infty)/2$, [K]
T_s	– surface temperature of fin, [K]
T_∞	– ambient temperature, [K]
t	– fin thickness, [mm]
U	– voltage, [V]
W	– width of fin heat exchanger, [m]

Greek symbols

α	– heat transfer coefficient, [Wm ⁻² K ⁻¹]
β	– volumetric expansion coefficient, [K ⁻¹]
ϵ	– emissivity [–]
ϵ_{ch}	– effective (apparent) channel emittance
λ	– thermal conductivity [Wm ⁻¹ K ⁻¹]
ν	– kinematic viscosity, [m ² s ⁻¹]
σ	– Stefan-Boltzmann constant [Wm ⁻² K ⁻⁴]

Subscripts

adj	– adjacent
ch	– channel
f	– fin
he	– heat exchanger
opt	– optimal
r	– radiation
s	– surface
∞	– ambient

References

- [1] Antonik, M., *et al.*, Performance and Design Comparison of a Bulk Thermoelectric Cooler With a Hybrid Architecture, *Journal of Thermal Science and Engineering Applications*, 8 (2016), 2
- [2] Ma, T., *et al.*, A Review on Thermoelectric-Hydraulic Performance and Heat Transfer Enhancement Technologies of Thermoelectric Power Generator System, *Thermal Science*, 22 (2018), 5, pp. 1885-1903
- [3] Xiao, G.-Q., *et al.*, Coupled Simulation of a Thermoelectric Generator Applied in Diesel Engine Exhaust Waste Heat Recovery, *Thermal Science*, 24 (2020), 1A, pp. 281-292
- [4] Ma, X., *et al.*, Building Integrated Thermoelectric Air Conditioners-A Potentially Fully Environmentally Friendly Solution in Building Services, *Future Cities and Environment*, 5 (2019), 12
- [5] Gondal, I. A., Design and Experimental Analysis of a Solar Thermoelectric Heating, Ventilation, and Air Conditioning System as an Integral Element of a Building Envelope, *Building Services Engineering Research and Technology*, 40 (2018), 2, pp. 220-236
- [6] Abbas, Z., *et al.*, Performance Evaluation of Novel Solar-Powered Domestic Air Cooler with Peltier Modules, *Journal of Mechanical Science and Technology*, 34 (2020), 11, pp. 4797-4807
- [7] Luo, Y., *et al.*, Dynamical Simulation of Building Integrated Photovoltaic Thermoelectric Wall System: Balancing Calculation Speed and Accuracy, *Applied Energy*, 3 (2017), Oct., pp. 887-897
- [8] Liu, Z., *et al.*, Experimental Evaluation of a Solar Thermoelectric Cooled Ceiling Combined with Displacement Ventilation System, *Energy Conversion and Management*, 87 (2014), 1, pp. 559-565
- [9] Irshad, K., *et al.*, Study of Thermoelectric and Photovoltaic Facade System for Energy Efficient Building Development: A Review, *Journal of Cleaner Production*, 209 (2019), Feb., pp. 1376-1395
- [10] Irshad, K., *et al.*, Thermal Comfort Study of a Building Equipped with Thermoelectric Air Duct System for Tropical Climate, *Applied Thermal Engineering*, 91 (2015), Dec., pp. 1141-1155
- [11] Rucinski, A., Rusowicz, A., Thermoelectric Generation of Current-Theoretical and Experimental Analysis, *Archives of Thermodynamics*, 38 (2017), 4, pp. 3-13

- [12] Cheng, T. H., *et al.*, An Effective Seebeck Coefficient Obtained by Experimental Results of a Thermoelectric Generator Module, *Applied Energy*, 88 (2011), 12, pp. 5173-5179
- [13] Wu, Z., *et al.*, Numerical Analysis of Semiconductor Thermoelectric Generator, *Thermal Science*, 24 (2020), 3A, pp. 1585-1591
- [14] Šumiga, I., *et al.*, Application of Thermoelectric Modules as Renewable Energy Sources, *Technical Journal*, 12 (2018), 3, pp. 151-158
- [15] Khanh, D. V. K., *et al.*, Optimization of Thermo-Electric Coolers Using Hybrid Genetic Algorithm and Simulated Annealing, *Archives of Control Sciences*, 24 (2014), 2, pp. 155-176
- [16] Trancossi, M., *et al.*, Thermoelectric and Solar Heat Pump Use Toward Self Sufficient Buildings: The Case of a Container House, *Thermal Science and Engineering Progress*, 18 (2020), 100509
- [17] Afshari, F., Experimental and Numerical Investigation on Thermoelectric Coolers for Comparing Air-To-Water to Air-to-Air Refrigerators, *Journal of Thermal Analysis and Calorimetry*, 144 (2020), 3, pp. 855-868
- [18] Chen, L. G., *et al.*, Performance Optimization of a Class of Combined Thermoelectric Heating Devices, *Science China Technological Sciences*, 63 (2020), Oct., pp. 2640-2648
- [19] Pupčević, M., *et al.*, Experimental Analysis of the Justification of Using a Space Heating System Based on Peltier Thermoelectric Generator, *Proceedings, IEEP Industrial Energy and Environmental Protection in the Countries of Southeast Europe*, Belgrade, Serbia, 2022
- [20] Bar-Cohen, A., Rohsenow, W. M., Thermally Optimum Spacing of Vertical, Natural Convection Cooled, Parallel Plates, *Journal of Heat Transfer*, 106 (1984), 1, pp. 116-123
- [21] Cengel, Y. A., Ghajar, A. J., *Heat and Mass Transfer-Fundamentals and Applications*, McGraw-Hill, New York, USA, 2011
- [22] Ahmadi, M., *et al.*, Natural Convection from Rectangular Interrupted Fins, *International Journal of Thermal Sciences*, 82 (2014), Aug., pp. 62-71
- [23] Yong, K. K., *et al.*, On the Role of Radiation View Factor in Thermal Performance of Straight-Fin Heat Sinks, *International Communications in Heat and Mass Transfer*, 37 (2010), 8, pp. 1087-1095
- [24] Shabany, Y., Radiation Heat Transfer from Plate-Fin Heat Sinks, *Proceedings, 24th Annual IEEE Semiconductor Thermal Measurement and Management Symposium*, San Jose, Cal., USA, 2008, pp. 132-136
- [25] Rea, S. N., West, S. E., Thermal Radiation from Finned Heat Sinks, *IEEE Transactions on Parts, Hybrids, and Packaging*, 12 (1976), 2, pp. 115-117
- [26] Fairuz, M. R., *et al.*, Experimental Study of a Mini Cooler by Using Peltier Thermoelectric Cell, *IOP Conference Series: Materials Science and Engineering*, 788 (2020), 5
- [27] Giaretto, V., Campagnoli, E., The Elusive Thomson Effect in Thermoelectric Devices. Experimental Investigation from 363 K to 213 K on Various Peltier Modules, *Metals*, 10 (2020), 291