

SUPPRESSION EFFECT OF CaCO₃, NaCl, AND NH₄H₂PO₄ ON GAS-FAT COAL DUST EXPLOSION PRESSURE AND FLAME CHARACTERISTICS

by

Tian-Qi LIU*, Xuan ZHAO, Wei-Ye TIAN, Rui-Heng JIA,
Ning WANG, and Zhi-Xin CAI

College of Safety Engineering, Shenyang Aerospace University, Shenyang, China

Original scientific paper
<https://doi.org/10.2298/TSCI220718141L>

Coal dust explosion is a major accident affecting the safety of coal mine production. In order to control coal dust explosion, using inert dust to suppress explosion is one of the effective methods. Taking the gas-fat coal as the research object and CaCO₃, NaCl, and NH₄H₂PO₄ as the inert dust, the suppression effect of inert dust on gas-fat coal dust explosion pressure and flame is studied. It is found that when the gas-fat coal dust particle size is 48~58 μm, both the maximum pressure and the farthest distance of flame reach the maximum value. Among the three inert dusts, NH₄H₂PO₄ has the best suppression effect, followed by NaCl, and CaCO₃ has the worst suppression effect on explosion. The smaller the particle size of NH₄H₂PO₄, the better the explosion suppression effect. When the mass percentage of NH₄H₂PO₄ mixed into gas-fat coal dust is 60%, and the particle size of NH₄H₂PO₄ is 0~38 μm, the explosion is completely suppressed, it is mainly due to the isolation of the coal dust particles from the oxygen and the dilution of the oxygen concentration.

Key words: gas-fat coal dust explosion, explosion pressure, explosion flame, suppression effect

Introduction

In China and even the world, coal is one of the main energy sources for human survival. Coal is widely distributed in the world. Due to different formation conditions, the degree of metamorphism of coal is also very different. In the process of coal mining, coal dust explosion seriously threatens the safety of mine workers [1]. Coal dust explosion will produce destructive pressure waves and flame waves, so explosion pressure and flame have always been the focus of attention at home and abroad [2, 3]. The explosion pressure can suspend the deposited coal dust, resulting in secondary explosions and multiple explosions, which are much more destructive than a single explosion [4, 5]. Therefore, in order to control the occurrence of coal dust explosions or reduce the losses caused by explosions, many methods of suppressing explosions have been proposed, among which the use of inert dusts to suppress explosions is a very common method [6, 7].

Coal dust explosion and combustible gas explosion have certain differences and some similarities. In the process of combustible gas explosion, the combustibles mainly react in the gas phase environment, and there is almost no particle phase in the reaction process [8-13]. In the process of coal dust explosion, there are both gas-phase reactions and particle-phase

* Corresponding author, e-mail: liutianqi613@163.com

reactions. After the coal dust particles are ignited, a large amount of combustible volatile gas is released, the combustible gas and combustible particles explode together, and a large amount of energy is released [14-18]. Relevant research results show that, under the same conditions, the intensity of the particle-phase explosion reaction is much greater than that of the gas-phase explosion [19-21]. Eckhoff [22] found that there are many influencing factors of dust explosion, and the factors affecting the explosion intensity of different dusts are different, which is the main cause of frequent accidents worldwide. Houim and Oran [23] studied the difference between coal dust explosion and gas explosion, and also discovered the structural characteristics of the explosion flame in the tube space, which is very important for understanding the evolution of flame waves. Kosinski and Hoffmann [24] used the numerical simulation method to study the process of the dust being ignited after rising in the tube space, the accuracy of the simulation results is acceptable.

In order to suppress coal dust explosion, the method of using inert dust has been proposed [25, 26]. In the process of coal mining, due to mechanical vibration and other reasons, a large amount of deposited coal dust will be generated in the tunnel. The deposited coal dust is an important factor that causes explosions. Therefore, in order to ensure production safety, the commonly used explosion suppression method is to spread inert dust in the tunnel at regular intervals [27-29]. Therefore, in order to suppress explosions more effectively, many types of inert dusts have been developed. But in the process of developing inert dust, not only the effectiveness of the suppression, but also the economics of the inert dust need to be considered [30, 31]. With the continuous breakthroughs in explosion suppression technology, it is hopeful that coal dust explosions will no longer occur through explosion suppression methods in the future, which is also the research goal of this paper.

In order to understand the formation mechanism and propagation process of coal dust explosion, the author of this paper discussed the influencing factors of explosion intensity in previous studies, revealed the correlation between coal dust cloud ignition and explosion, and found the formation conditions and propagation characteristics of the secondary explosion of coal dust [32-36]. However, there is a lack of research on the suppression effect of different inert dusts on the explosion pressure and flame of gas-fat coal in the relevant previous research. In this paper, in order to study the suppression effect of inert dust on coal dust explosion, CaCO_3 , NaCl , and $\text{NH}_4\text{H}_2\text{PO}_4$ are selected as inert dust, and gas-fat coal is selected as coal dust sample, the suppression effect of inert dust on the explosion pressure and flame of gas-fat coal dust is analyzed. The research results are of great significance for comparing the explosion suppression effects of different types of inert dusts.

Experimental equipments and samples

Experimental equipments

In this paper, two experimental equipments are used, one of which is used to test the coal dust explosion pressure, and the other is used to test the coal dust explosion flame. The author has already introduced the explosion flame test equipment in detail in the literature [29-33], so it will not be introduced again here. In the process of coal dust explosion flame test, the flame propagation distance increases with time. The maximum flame propagation distance along the pipe-line is called the furthest propagation distance of flame, which is abbreviated as l_{max} .

In addition, according to China's national standard *GB/T 16426-1996 dust cloud maximum explosion pressure and determination method of explosion index*, to test coal dust explosion pressure data, experiments are carried out using the coal dust explosion pressure test equipment shown in fig. 1. In the process of coal dust explosion pressure test, as time increases, the

explosion pressure will continuously increase to the maximum value, and then decrease again. The maximum value that the explosion pressure can reach in the explosion space is called the maximum explosion pressure, which can be abbreviated as P_{max} . The volume of the explosion space inside the equipment is 20 liters. This explosive equipment can be remotely controlled, so the experiment process can be guaranteed to be safe.

The coal dust explosion pressure test process is as follows. First, put the dust sample in the dust storage tank. Then after coal dust particles explode in the explosion space, the explosion pressure data will be recorded, and a pressure curve will be formed, through which it can be judged whether the explosion occurred and the magnitude of the explosion intensity. Finally, start the water circulation system, which can quickly reduce the temperature of the explosion space and reduce the experimental period. In addition, the ignition energy in this experiment is 10 kJ, which can provide sufficient energy for coal dust explosion.

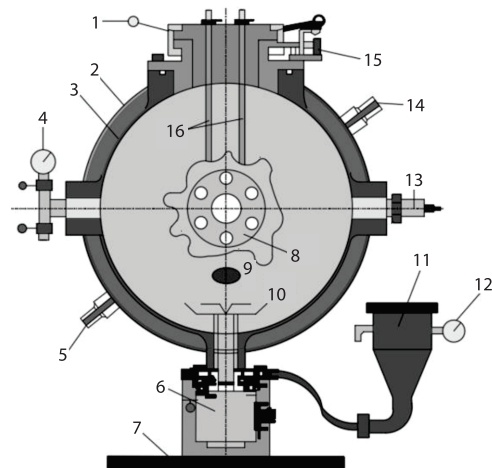

Figure 1. Structure diagram of explosion pressure test equipment: 1 – sealing cap, 2 – outer side of mezzanine, 3 – inside of mezzanine, 4 – vacuum gauge, 5 – outlet of water, 6 – mechanical two-way valve, 7 – base, 8 – observation window, 9 – vacuum hole, 10 – dispersion valve, 11 – storage tank, 12 – pressure gauge, 13 – pressure sensor, 14 – inlet of water, 15 – limit switch, and 16 – ignition rod

Experimental samples

Gas-fat coal dust sample

The gas-fat coal dust sample used in this paper is from Shandong Energy New Mine Group in China. The coking property of gas-fat coal is better than gas coal but inferior to fat coal. Therefore, gas-fat coal is most suitable for high temperature dry distillation produce coal gas. In the process of gas-fat coal mining, explosion suppression is very important for safe production. The main components of the coal samples are shown in tab. 1, wherein the proximate analysis results are obtained by using an proximate analyzer, and the ultimate analysis results are obtained by using an ultimate analyzer. Gas-fat coal is a kind of high volatile coal, the low heating value of coal sample is 29307.6 kJ/kg, and the carbon content in the sample exceeds 60%, indicating that the explosion danger of the sample is very high.

Table 1. Main components of gas-fat coal dust sample

Proximate analysis [%]				Ultimate analysis [%]			
M_{ad}	A_{ad}	V_{ad}	FC_{ad}	C_{ad}	H_{ad}	O_{ad}	N_{ad}
5.79	6.71	39.28	48.22	61.80	3.96	30.15	4.09

Note: M_{ad} is the air-dried moisture, A_{ad} – the air-dried ash, V_{ad} – the air-dried volatile, and FC_{ad} – the air-dried fixed carbon.

According to China's national standard *GB 474-2008 preparation method of coal samples*, the preparation of coal samples was carried out. The preparation process of coal samples mainly included the collection, sieving and drying of coal samples. The sample is sieved with a vibrating sieve machine, and the particle size distribution of the sample is tested using

a morphology analysis device. The particle size of the sample is greater than 58 μm and less than 75 μm , and the particle size distribution is normal distribution. Within this particle size range, the coal dust sample has a certain explosiveness, which can meet the needs of explosion experiments.

Inert dust samples

In this paper, the suppression effect of inert dust on gas-fat coal dust explosion is studied by mixing inert dust into gas-fat coal dust. As shown in fig. 2, CaCO₃, NaCl, and NH₄H₂PO₄ are selected as inert dust. The CaCO₃ is an inorganic compound, which is the main component of limestone and marble. Its melting point exceeds 1500 K, and at the same time, it is widely distributed around the world, so it can be used as an explosion-suppressed inert dust. The NaCl is an inorganic ionic compound, which is mainly derived from seawater. Its melting point exceeds 1000 K, and it is an inert dust that has been gradually used in recent years. The NH₄H₂PO₄ is an emerging chemical agent, which is one of the main components of fire extinguishers. When it comes into contact with an ignition source, it will decompose, releasing products that suppress the explosion and absorbing a lot of heat.



Figure 2. Inert dust samples; (a) CaCO₃, (b) NaCl, and (c) NH₄H₂PO₄

Results and discussion

Gas-fat coal dust explosion pressure and flame characteristics

In the experiments of this paper, P_{max} is mainly used to reflect the explosion pressure characteristic, and l_{max} is mainly used to reflect the explosion flame characteristics. The coal dust explosion results obtained from the experiments are shown in tab. 2. The P_{max} of gas-fat coal dust explosion is 0.67 MPa, and l_{max} of gas-fat coal dust explosion is 0.64 m. In the experiment of coal dust explosion pressure and flame characteristics, the mass concentration of coal dust cloud is 300 g/m³, and the particle size of coal dust is 58-75 μm . In order to study the effect of coal dust particle size on explosion pressure and flame characteristics, further research will be carried out in the next section.

Table 2. Test results of gas-fat coal dust explosion pressure and flame characteristics

Mass concentration of coal dust cloud [gm ⁻³]	Particle size [μm]	Test results	
		P_{max} [MPa]	l_{max} [m]
300	58~75	0.67	0.64

Note: P_{max} is the maximum pressure and l_{max} – the farthest propagation distance of flame.

Explosion pressure and flame of gas-fat coal dust with different particle sizes

In section *Gas-fat coal dust explosion pressure and flame characteristics*, the particle size of gas-fat coal dust is 58-75 μm. In this section, the mass concentration of coal dust cloud is still 300 g/m³, but coal dust samples of 0-25 μm, 25-38 μm, 38-48 μm, and 48-58 μm are prepared by a sieving machine for explosion experiments. The experimental results are shown in tab. 3, first of all, it can be seen that the particle size of coal dust has a certain influence on the explosion pressure and flame. When the gas-fat coal dust particle size is 48~58 μm, both P_{max} and l_{max} reach the maximum value. The maximum value of P_{max} is 0.69 MPa, and the maximum value of l_{max} is 0.68 m. When the particle size of coal dust is less than 48 μm, the values of P_{max} and l_{max} are smaller than those when the particle size is 48~58 μm, and the smaller the particle size in the range of 0~48 μm, the smaller the values of P_{max} and l_{max} . The results of this study are consistent with the results reported in related literature [19-21].

Under the premise of the same mass concentration of gas-fat coal dust cloud, the gas-fat coal dust particle size that makes P_{max} and l_{max} reach the maximum value is 48~58 μm, not 58-75 μm, indicating that when the particle size is greater than 58 μm, the heat released by the coal dust particles in the explosion is limited. When the particle size is less than 48 μm, the explosion intensity does not continue to increase. This is because the particle size becomes too small, which will cause the particle size to become gas. This process is endothermic, so the explosion pressure and flame will decrease.

Table 3. Explosion pressure and flame of gas-fat coal dust with different particle sizes

c [gm ⁻³]	r [μm]	Explosion pressure and flame characteristics	
		P_{max} [MPa]	l_{max} [m]
300	0~25	0.51	0.52
300	25~38	0.62	0.57
300	38~48	0.68	0.63
300	48~58	0.69	0.68
300	58~75	0.67	0.64

Note: c is the gas-fat coal dust cloud mass concentration and r – the gas-fat coal dust particle size.

Suppression effect of inert dust on gas-fat coal dust explosion pressure and flame

In the explosion suppression experiment, the selected inert dusts are CaCO₃, NaCl, and NH₄H₂PO₄. According to the results in section *Explosion pressure and flame of gas-fat coal dust with different particle sizes*, since the explosion intensity is the largest when the gas-fat coal dust particle size is 48-58 μm, in this section, the gas-fat coal dust particle size is 48~58 μm, and the mass concentration of gas-fat coal dust cloud is still 300 g/m³. The particle sizes of the three inert dusts are also 48-58 μm. During the explosion suppression experiment, inert dusts are mixed into gas-fat coal dust in different mass percentages. The experimental results of explosion suppression are shown in tab. 4. It can be found that three types of inert dusts have a certain suppression effect on gas-fat coal dust explosion. The NH₄H₂PO₄ has the best

suppression effect, followed by NaCl, and CaCO₃ has the worst suppression effect on explosion. Therefore, in terms of explosion suppression effect, NH₄H₂PO₄ is the most effective inert dust. But from an economic point of view, CaCO₃ is the most economical inert dust, because CaCO₃ has a wide range of sources and a very low price, which is why coal mines often use CaCO₃ as inert dust at present. When p is 70%, NH₄H₂PO₄ completely suppressed the gas-fat coal dust explosion, and the explosion pressure and flame data obtained from the test showed that no explosion occurred, which verifies the suppression effect of NH₄H₂PO₄.

Table 4. Suppression effect of inert dusts on explosion pressure and flame

P [%]	CaCO ₃		NaCl		NH ₄ H ₂ PO ₄	
	P_{\max} [MPa]	l_{\max} [m]	P_{\max} [MPa]	l_{\max} [m]	P_{\max} [MPa]	l_{\max} [m]
0	0.69	0.68	0.69	0.68	0.69	0.68
10	0.65	0.63	0.64	0.62	0.62	0.60
20	0.62	0.58	0.60	0.56	0.53	0.53
30	0.58	0.54	0.55	0.51	0.44	0.45
40	0.55	0.50	0.52	0.45	0.37	0.38
50	0.52	0.47	0.48	0.40	0.30	0.29
60	0.49	0.43	0.43	0.35	0.25	0.22
70	0.45	0.39	0.39	0.28	–	–

Note: p is the mass percentage of inert dust mixed into gas-fat coal dust.

In figs. 3 and 4, the suppression effect of inert dust on explosion pressure and flame can be seen. When p is 0%, P_{\max} and l_{\max} are 0.69 MPa and 0.68 m, respectively. When CaCO₃ is used for explosion suppression and p is increased to 70%, P_{\max} and l_{\max} are reduced to 0.45 MPa and 0.39 m, respectively. The P_{\max} and l_{\max} decrease by 0.24 MPa and 0.29 m, respectively. In contrast, when NH₄H₂PO₄ is used for explosion suppression and p is increased to 60%, P_{\max} and l_{\max} are reduced to 0.25 MPa and 0.22 m, respectively. The P_{\max} and l_{\max} decrease by 0.44 MPa and 0.46 m, respectively. The above explosion suppression data show that NH₄H₂PO₄ has the best explosion suppression effect among the three types of inert dusts. Therefore, in order to study the effect of the particle size of NH₄H₂PO₄ on the explosion suppression, it will be further investigated in the next section.

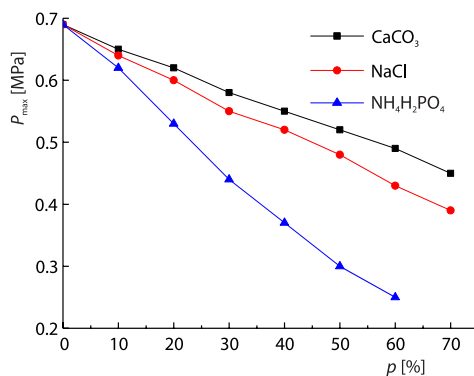

Figure 3. Suppression effect on P_{\max}

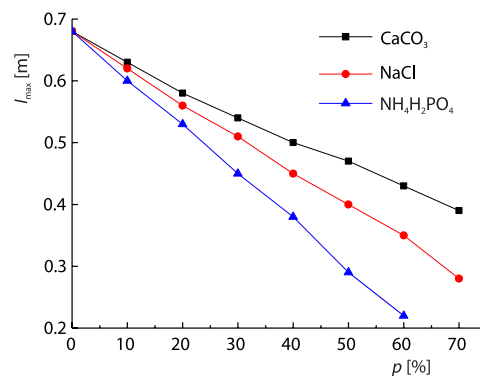

Figure 4. Suppression effect on l_{\max}

Influence of particle size of NH₄H₂PO₄ on suppression effect of gas-fat coal dust explosion

In section *Suppression effect of inert dust on gas-fat coal dust explosion pressure and flame*, the particle size of the inert dust is 48-58 μm. In this section, NH₄H₂PO₄ with different particle sizes is used for explosion suppression experiments. The particle size of gas-fat coal dust used in the experiment is 48-58 μm, and the mass concentration of gas-fat coal dust cloud is 300 g/m³. In tab. 5 shows the suppression effect of NH₄H₂PO₄ with different particle sizes on gas-fat coal dust explosion. The NH₄H₂PO₄ of different particle sizes is mainly screened out by vibrating screen machine and screen with different mesh numbers. When the particle size of NH₄H₂PO₄ is 0-25 μm, the larger the *p* is, the smaller *P*_{max} and *l*_{max} are. When *p* is 60%, and the particle size of NH₄H₂PO₄ is 0-38 μm, the explosion is completely suppressed, and the explosion pressure and flame are not monitored. When *p* is 70%, and the particle size of NH₄H₂PO₄ is 0-75 μm, the explosion no longer occurs, which fully shows that the suppression effect of NH₄H₂PO₄ on gas-fat coal dust explosion is very good.

Table 5. Influence of particle size of NH₄H₂PO₄ on suppression effect

<i>P</i> [%]	0-25 μm		25-38 μm		38-48 μm		48-58 μm		58-75 μm	
	<i>P</i> _{max} [MPa]	<i>l</i> _{max} [m]	<i>P</i> _{max} [MPa]	<i>l</i> _{max} [m]	<i>P</i> _{max} [MPa]	<i>l</i> _{max} [m]	<i>P</i> _{max} [MPa]	<i>l</i> _{max} [m]	<i>P</i> _{max} [MPa]	<i>l</i> _{max} [m]
0	0.69	0.68	0.69	0.68	0.69	0.68	0.69	0.68	0.69	0.68
10	0.56	0.54	0.58	0.56	0.60	0.58	0.62	0.60	0.63	0.63
20	0.46	0.48	0.49	0.50	0.51	0.52	0.53	0.53	0.55	0.56
30	0.38	0.39	0.40	0.41	0.42	0.43	0.44	0.45	0.48	0.48
40	0.29	0.31	0.31	0.33	0.33	0.36	0.37	0.38	0.42	0.41
50	0.21	0.22	0.22	0.24	0.26	0.27	0.30	0.29	0.35	0.32
60	–	–	–	–	0.21	0.20	0.25	0.22	0.27	0.25
70	–	–	–	–	–	–	–	–	–	–

Note: *p* is the mass percentage of NH₄H₂PO₄ mixed into gas-fat coal dust.

Figures 5 and 6 are the curves of NH₄H₂PO₄ with different particle sizes on explosion suppression. It can be seen more intuitively from the figures that as *p* increases, *P*_{max} and *l*_{max} continue to decrease. At the same time, the smaller the particle size of NH₄H₂PO₄, the better the effect of suppressing the explosion. In figs. 5 and 6, it can be seen that there is a clear boundary between different explosion suppression curves, indicating that the smaller the particle size of NH₄H₂PO₄, the more fully mixed with coal dust particles during explosion, so that NH₄H₂PO₄ occupies more spaces between the coal dust particles, which better hinders the heat transfer between the coal dust particles, thereby greatly reducing the explosion intensity.

Among the three types of inert dusts selected in this paper, NH₄H₂PO₄ has the best explosion suppression effect. Under the condition of heating NH₄H₂PO₄, the products NH₃, H₂O, and P₂O₅ are formed. The NH₃ is a gaseous product that dilutes the oxygen concentration and reduces the rate of the explosive reaction. The H₂O is also a gas product, which can separate coal dust particles from oxygen, so that sufficient oxygen cannot be obtained during the explosion process, thereby effectively suppressing the explosion. The P₂O₅ is a solid product, which can adhere to the surface of coal dust particles, separate the coal dust particles from oxygen, and effectively control the heat transfer between particles.

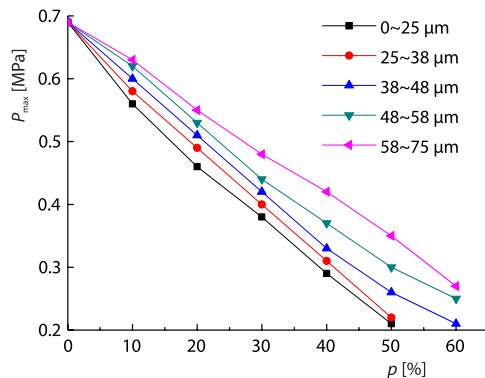
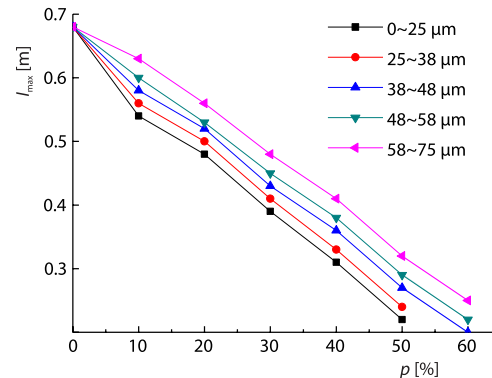
Figure 5. Suppression effect on P_{\max} Figure 6. Suppression effect on l_{\max}

Conclusions

In this paper, the suppression effect of CaCO_3 , NaCl , and $\text{NH}_4\text{H}_2\text{PO}_4$ on gas-fat coal dust explosion pressure and flame is discussed. The conclusions of this study are as follows.

- The particle size of gas-fat coal dust has a certain influence on the explosion pressure and flame. When the gas-fat coal dust particle size is 48-58 μm , both P_{\max} and l_{\max} reach the maximum value. The smaller the gas-fat coal dust particle size in the range of 0-48 μm , the smaller the values of P_{\max} and l_{\max} .
- The CaCO_3 , NaCl , and $\text{NH}_4\text{H}_2\text{PO}_4$ have a certain suppression effect on gas-fat coal dust explosion. The $\text{NH}_4\text{H}_2\text{PO}_4$ has the best suppression effect, followed by NaCl , and CaCO_3 has the worst suppression effect on explosion. When p is 70%, $\text{NH}_4\text{H}_2\text{PO}_4$ completely suppressed the gas-fat coal dust explosion. When $\text{NH}_4\text{H}_2\text{PO}_4$ is used for explosion suppression and p is increased to 60%, P_{\max} and l_{\max} decrease by 0.44 MPa and 0.46 m, respectively.
- The smaller the particle size of $\text{NH}_4\text{H}_2\text{PO}_4$, the better the effect of suppressing the explosion. When p is 60%, and the particle size of $\text{NH}_4\text{H}_2\text{PO}_4$ is 0-38 μm , the explosion is completely suppressed. When p is 70%, and the particle size of $\text{NH}_4\text{H}_2\text{PO}_4$ is 0-75 μm , the explosion no longer occurs. Under the condition of heating $\text{NH}_4\text{H}_2\text{PO}_4$, the products NH_3 , H_2O , and P_2O_5 can dilute the oxygen concentration and separate the coal dust particles from oxygen, thus effectively controlling the intensity of the explosion.

Acknowledgment

The authors appreciate the financial support from the National Natural Science Foundation of China (Grant No. 12102271), the Project of Liaoning Provincial Department of Science and Technology (Grant No. 2020-BS-175), the Project of Liaoning Provincial Department of Education (Grant No. JYT19038).

References

- [1] Eckhoff, R. K., Current Status and Expected Future Trends in Dust Explosion Research, *Journal Loss Prev. Process Ind.*, 18 (2005), 4-6, pp. 225-237
- [2] Joseph, G., Combustible Dusts: A Serious Industrial Hazard, *Journal Hazard. Mater.*, 142 (2007), 3, pp. 589-591
- [3] Niu, Y. H., *et al.*, Experimental Study on the Explosion-Propagation Law of Coal Dust with Different Moisture Contents Induced by Methane Explosion, *Powder Technol.*, 361 (2020), Feb., pp.507-511
- [4] Ban, T., *et al.*, Thermodynamics of the Coal Dust Explosion: Main Factors and Optimal Control, *Thermal Science*, 26 (2022), 3B, pp. 2477-2483

- [5] Lin, S., *et al.*, Comparison on the Explosivity of Coal Dust and of Its Explosion Solid Residues to Assess the Severity of Re-Explosion, *Fuel*, 251 (2019), Apr., pp. 438-446
- [6] Ban, T., *et al.*, Effect of Ignition Energy on Coal Dust Explosion, *Thermal Science*, 24 (2020), 4, pp. 2621-2628
- [7] Cao, W. G., *et al.*, Experimental Study on the Combustion Sensitivity Parameters and Pre-combusted Changes in Functional Groups of Lignite Coal Dust, *Powder Technol.*, 283 (2015), Jun., pp. 512-518
- [8] Zheng, K., *et al.*, Explosion Behavior of Non-Uniform Methane/Air Mixture in an Obstructed Duct with Different Blockage Ratios, *Energy*, 255 (2022), Sep., 124603
- [9] Zheng, K., *et al.*, Effect of Obstacle Location on Explosion Dynamics of Premixed H₂/CO/Air Mixtures in a Closed Duct, *Fuel*, 324 (2022), Jun., 124703
- [10] Zheng, K., *et al.*, Application of Large Eddy Simulation in Methane-air Explosion Prediction Using Thickening Flame Approach, *Process Safety and Environmental Protection*, 159 (2022), Jan., pp. 662-673
- [11] Cheng, Y. F., *et al.*, Influential Factors on the Explosibility of the Unpremixed Hydrogen/Magnesium Dust, *Int. J. Hydrog. Energy*, 45 (2020), 58, pp. 34185-34192
- [12] Cheng, Y. F., *et al.*, Combustion Behaviors and Explosibility of Suspended Metal Hydride TiH₂ Dust, *Int. J. Hydrog. Energy*, 45 (2020), 21, pp. 12216-12224
- [13] Cheng, Y. F., *et al.*, Hybrid H₂/Ti Dust Explosion Hazards During the Production of Metal Hydride TiH₂ in a Closed Vessel, *Int. J. Hydrog. Energy*, 44 (2019), 21, pp. 11145-11152
- [14] Cheng, Y. F., *et al.*, An Improved Two-Color Pyrometer Based Method for Measuring Dynamic Temperature Mapping of Hydrogen-Air Combustion, *Int. J. Hydrog. Energy*, 46 (2021), 69, pp. 34463-34468
- [15] Zhu, C., *et al.*, Experimental Study on the Effect of Bifurcations on the Flame Speed of Premixed Methane/Air Explosions in Ducts, *Journal Loss Prev. Process. Ind.*, 49 (2017), May, pp. 545-550
- [16] Cao, W. G., *et al.*, Under-Expansion Jet Flame Propagation Characteristics of Premixed H₂/Air in Explosion Venting, *Int. J. Hydrog. Energy*, 46 (2021), 78, pp. 1402-1405
- [17] Cao, W. G., *et al.*, The Flow Field Behaviours of Under-Expansion Jet Flame in Premixed Hydrogen/Air Explosion Venting, *Int. J. Hydrog. Energy*, 47 (2022), 18, pp. 10420-10430
- [18] Zhang, P., *et al.*, Explosions of Gasoline-Air Mixture in the Tunnels Containing Branch Configuration, *Journal Loss Prev. Process. Ind.*, 26 (2013), May, pp. 1279-1284
- [19] Cao, W., *et al.*, Experimental and Numerical Study on Flame Propagation Behaviors In Coal Dust Explosions, *Powder Technol.*, 266 (2014), Jun., pp. 456-462
- [20] Gao, W., *et al.*, Effects of Particle Size Distributions on Flame Propagation Mechanism During Octadecanol Dust Explosions, *Powder Technol.*, 249 (2013), Aug., pp. 168-174
- [21] Gao, W., *et al.*, Effects of Particle Thermal Characteristics on Flame Structures during Dust Explosions of Three Long-Chain Monobasic Alcohols in an Open-Space Chamber, *Fuel*, 113 (2012), May, pp. 86-96
- [22] Eckhoff, R. K., Understanding Dust Explosions, The Role of Powder Science and Technology, *Journal Loss Prev. Process Ind.*, 22 (2009), 1, pp. 105-116
- [23] Houim, R. W., Oran, E. S., Structure and Flame Speed of Dilute and Dense Layered Coal-Dust Explosions, *Journal Loss Prev. Process Ind.*, 36 (2015), Jan., pp. 214-222
- [24] Kosinski, P., Hoffmann, A., An Investigation of the Consequences of Primary Dust Explosions in Interconnected Vessels, *Journal Hazard. Mater.*, 137 (2006), 2, pp. 752-761
- [25] Wei, X. R., *et al.*, Study on Explosion Suppression of Coal Dust with Different Particle Size by Shell Powder and NaHCO₃, *Fuel*, 306 (2021), Dec., pp. 224-239
- [26] Liu, Q. M., *et al.*, Methane/Coal Dust/Air Explosions and Their Suppression by Solid Particle Suppressing Agents in a Large-Scale Experimental Tube, *Journal Loss Prev. Process Ind.*, 26 (2013), 2, pp. 310-316
- [27] Cao, W. G., *et al.*, Flame-Propagation Behavior and a Dynamic Model for the Thermal-Radiation Effects in Coal-Dust Explosions, *Journal Loss Prev. Process Ind.*, 29 (2014), 1, pp. 65-71
- [28] Cao, W. G., *et al.*, Experimental and Numerical Studies on the Explosion Severities of Coal Dust/Air Mixtures in a 20-L Spherical Vessel, *Powder Technol.*, 310 (2017), Jan., pp. 17-23
- [29] Song, Y. F., *et al.*, Explosion Energy of Methane/Deposited Coal Dust and Inert Effects of Rock Dust, *Fuel*, 228 (2018), Sept., pp. 112-122
- [30] Wang, X., *et al.*, Numerical Simulation of Coal Dust Explosion Suppression by Inert Particles in Spherical Confined Storage Space, *Fuel*, 253 (2019), Oct., pp. 1342-1350
- [31] Lu, K. L., *et al.*, The Inhibiting Effects of Sodium Carbonate on Coal Dust Deflagration Based on Thermal Methods, *Fuel*, 315 (2022), May, pp. 122-135
- [32] Liu, T. Q., *et al.*, Experimental and Numerical Study on Coal Dust Ignition Temperature Characteristics and Explosion Propagation Characteristics in Confined Space, *Combust. Sci. Technol.*, On-line first, <https://doi.org/10.1080/00102202.2021.2010722>, 2021

- [33] Liu, T. Q., *et al.*, Flame Propagation and CO/CO₂ Generation Characteristics of Lignite Dust Explosion in Horizontal Pipe-line, *Int. J. Low Carbon Technol.*, 16 (2021), 4, pp. 1384-1390
- [34] Liu, T. Q., *et al.*, Research on Ignition Energy Characteristics and Explosion Propagation Law of Coal Dust Cloud Under Different Conditions, *Math. Probl. Eng.*, 11 (2021), Sept., pp. 21-28
- [35] Liu, T. Q., *et al.*, Prediction Method of Coal Dust Explosion Flame Propagation Characteristics Based on Principal Component Analysis and BP Neural Network, *Math. Probl. Eng.*, 6 (2022), Mar., pp. 41-49
- [36] Liu, T. Q., *et al.*, Flame Propagation Characteristics of Deposited Coal Dust Explosion Driven by Air-Flow Carrying Coal Dust, *Journal Chem. Eng. Jpn.*, 54 (2021), 12, pp. 631-637