

## MODELING OF THE BUCKSTAY SYSTEM OF MEMBRANE WALLS IN WATERTUBE BOILER CONSTRUCTION

by

**Hasan M. NAGIAR, Taško D.J. MANESKI\*, Vesna O. MILOŠEVIĆ-MITIĆ,  
Branka M. GAČEŠA and Nina M. ANDJELIĆ**

Faculty of Mechanical Engineering, University of Belgrade, Belgrade, Serbia

Original scientific paper  
DOI: 10.2298/TSCI120204174N

*Membrane walls are very important structural parts of water-tube boiler construction. Based on their specific geometry, one special type of finite element was defined to help model the global boiler construction. That is the element of reduced orthotropic plate with two thicknesses and two elasticity matrixes, for membrane and bending load separately. A global model of the boiler construction showed that the high value of stress is concentrated in plates of the buckstay system in boiler corners. Validation of the new finite element was done on the local model of the part of membrane wall and buckstay. A very precise model of tubes and flanges was compared to the model formed on the element of a reduced orthotropic plate. Pressure and thermal loads were discussed. Obtained results indicated that the defined finite element was quite favorable in the design and reconstruction of the boiler substructures such as a buckstay system.*

*Key words: membrane wall, watertube boiler, temperature, stress, deformation, reduced orthotropic plate, buckstay*

### Introduction

The current concept of water-tube boiler construction is based on membrane walls (tube wall panels) because they are very important structural parts. As membrane walls have specific unisotropic geometry, they have been stiffened with the buckstay system placed to prevent large deformations. Water-tube boilers are often designed for high steam pressures and high temperatures. Walls of the chambers are exposed to failures in angular connections close to the buckstay system, arise during large temperature changes at the start and quit boiler regimes. Norms provide formulas for strength calculation of pressurized elements in boiler constructions and define temperature-dependent allowable stresses. But they do not explicitly consider the influence of the thermal stresses and local stress concentration. This problem can be solved by applying the finite element method.

Taljat *et al.* [1] carried out thermomechanic analysis for the membrane walls of composite tubes for the black liquor recovery boiler. Residual welded stresses were calculated and involved in the wall model. The problem of the membrane wall contraction during sedimentation of stainless-steel on a damaged panel was considered in [2].

---

\* Corresponding author, e-mail: tmaneski@mas.bg.ac.rs

A proposal for partial replacement of boiler wall-tubes was defined in [3] and a sequence of service recommendations how to prevent the occurrence of wall tubing damage was also given. Othman et al. [4] showed that temperature is the most important factor in failure investigation on deformed horizontal superheater tube. In paper [5] the influence of the welded shanks between superheater tubes on high temperature stresses near the welds was considered.

Disregarding thermal dilatations of the boiler construction, in the process of boiler design, leads to premature damage in boiler exploitation. Recent approach to the estimation of boiler integrity using FEM on fire-tube boiler construction was presented in [6]. The methodological approach for the state analysis of the boiler pipe system in the case of hot-water boiler VKL50 and methods for testing the parent metal and welded joints were shown in [7]. As a result of thermal fatigue, the dilatation of steam pipe line at an operating temperature may lead to cracks initiation in the critical zones within heat affected zone of steam pipe line welded joints [8]. Analytical modeling of some alloy resistance spot welding process has been developed in [9] on the basis of thermomechanical conservation laws. The numerical solution was obtained by the finite element method. Methodology of condition and behavior diagnostics for boiler constructions that was necessary for decision-making on further operation was presented in [10]. An algorithm was defined to illustrate the methods of collecting data needed for diagnostics.

The distance in thermal dilatations on the coupled components of the steam boiler can lead to large plastic deformations and increase of dynamic strength. One multifield finite element approach to the analysis of the behaviour of solid bodies under thermal loading was presented in [11]. Membrane walls can be modeled using finite elements of thin orthotropic plate [12]. This produces decreasing in nodal points and elements of the global model of the boiler construction and reduced calculation time. Stress calculation in stationary temperature field for some type of fibre composite materials and metallic parts was shown in [13], based on FEM.

In this paper, one new sub-type of finite element of the orthotropic plate is presented. The element is defined using two thicknesses and two appropriate elasticity matrixes of the material. The first thickness and first matrix correspond to the membrane load and the second ones to the bending load. The procedure for defining a new finite element is presented on the membrane wall of the water-tube boiler type VU60. Numerical model of the global structure of the boiler, as well as the results for deformation and stress fields are shown. Validation of the new finite element is done on the local model of the part of membrane wall and buckstay. A very precise model of tubes and flanges is compared to the model based on the new type of finite element. The pressure and thermal loads are discussed and the calculated results indicate that the defined finite element is quite favorable in the design and reconstruction of the boiler substructures such as a buckstay system.

### **Modeling of the membrane wall using finite element of reduced orthotropic plate**

#### *Membrane wall*

Membrane wall of water-tube boiler type VU60 consists of tubes diameter 71.6 mm and thickness 4.5 mm with welded bands thickness 6 mm. Tube distance is 102 mm. Elastic characteristics of the steel for the temperature  $T = 321$  °C are: Modulus of elasticity  $E = 183$  GPa and Poisson's ratio  $\nu = 0.328$ .

Membrane wall was placed in plane 1-2 and direction 1 was adopted as a tube direction. The finite element model of the membrane wall dimension  $612 \times 612$  mm was formed. Corresponding deformations (longitudinal and transversal) due to membrane mechanical load and due to pressure load (normal on plane 1-2) were calculated.

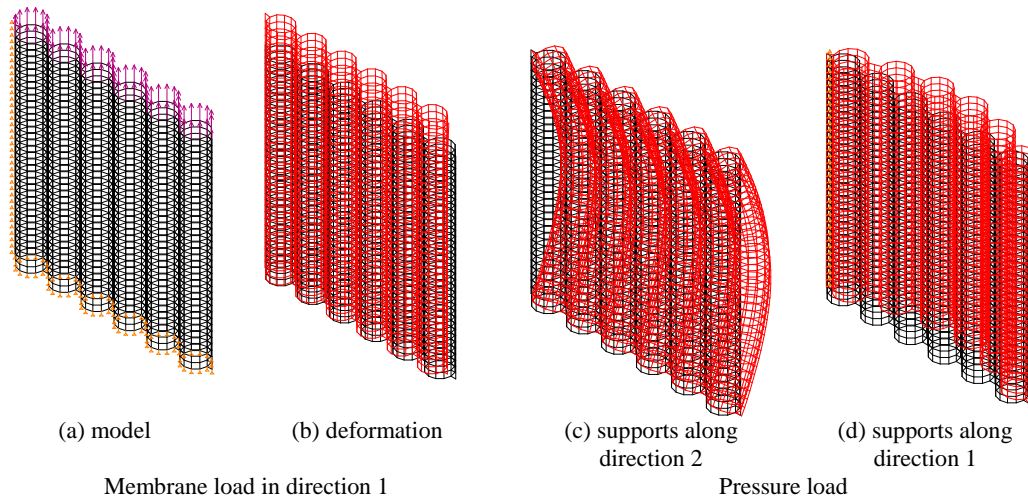

**Figure 1. Membrane wall under the load in direction 1 and under the pressure load**

In the first step, supports were placed along two adjacent edges. The panel was loaded with forces acting along the axis 1 with the total load of 500 Kn, fig. 1(a). Obtained deformation field is presented in fig. 1(b). In the second step, the panel was loaded in the other direction with the same load. Calculated results for longitudinal and transversal deformations are presented in tab. 1.

**Table 1. Longitudinal and transversal displacements of the membrane wall. Deflection of the middle point under the pressure load**

Load	Membrane load		Bending load (pressure)	
	Longitudinal displacement	Transversal displacement	Supports	Deflection of the middle point
In direction 1	0.234 mm	0.078 mm	Along direction 1	1.8 mm
In direction 2	20.28 mm	0.083 mm	Along direction 2	160 mm

A similar analysis was provided for the equable pressure normal to the plane 1-2. Membrane wall was loaded with the pressure of the intensity 1 MPa, while the supports were placed along the opposite edges. Deflection of the middle point of the panel was chosen as a reference value. Calculated results are shown in Table 1. Figures 1(c) and 1(d) represent the corresponding dilatations. Implemented analysis of the membrane wall behavior shows that wall stiffness in direction 1 is much higher than wall stiffness in direction 2. In both loading cases this correlation is about 88.

*Elasticity properties of the reduced orthotropic plate*

Membrane walls are an important structural part for strength analysis of the water-tube boiler. They can be modeled using finite element of an orthotropic plate that leads to decreasing in node and element numbers of the global and local boiler model.

An elasticity matrix for the orthotropic plate was defined to have the equivalent behavior characteristics as the membrane wall. If the direction 1 is the tube direction and direction 2 is normal to it, the elasticity matrix for the orthotropic material (plane state of stress) [14] is

$$\begin{bmatrix} \frac{E_1}{1-\nu_{12}\nu_{21}} & \frac{\nu_{21}E_1}{1-\nu_{12}\nu_{21}} & 0 \\ \frac{\nu_{21}E_1}{1-\nu_{12}\nu_{21}} & \frac{E_2}{1-\nu_{12}\nu_{21}} & 0 \\ 0 & 0 & G_{12} \end{bmatrix} \quad (1)$$

where

$$\nu_{12}E_2 = \nu_{21}E_1. \quad (2)$$

In the linear theory of thin plates, membrane load is not coupled with the bending load, so the corresponding elasticity matrixes can be obtained separately.

To define elasticity matrixes for a reduced orthotropic plate, initially, its depth has to be chosen. The axial moment of inertia for the membrane wall cross-section for the axis 2 is equal to the one of the plate thickness of 37 mm. The surface of the wall cross-section corresponds to the plate thickness of 11.7 mm. So, a new finite element with two thicknesses and two elasticity matrixes has been defined. Plate thickness of 30 mm was adopted for the bending load and thickness of 10 mm for the membrane load. So, the finite element model of the isotropic plate was formed with Modulus of elasticity  $E=183$  GPa and Poisson's ratio  $\nu=0.334$ .

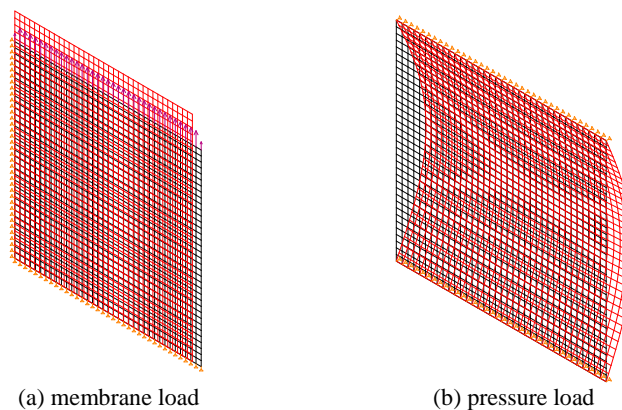

**Figure 2. Deformation of the plate**

Supports and concentrated forces were distributed according to the model of the membrane wall. The corresponding plate deformation is presented in fig. 2a. Calculated results are shown in tab. 2.

**Table 2. Longitudinal and transversal plate displacements**

Membrane load	Longitudinal displacement	Transversal displacement
500 kN	0.273 mm	0.0913 mm

Obtained results for longitudinal and transversal deformations of membrane wall presented in Table 1 gave the following values of Poisson's ratios

$$\nu_{12} = 0.334 \text{ and } \nu_{21} = 0.004. \quad (3)$$

Comparison of the results presented in Tables 1 and 2 gave fictive modulus of elasticity according to the membrane load in direction 1 as  $E_{1m} = 213.9$  GPa. Using relation (2), together with values from (3), the fictive elasticity modulus according to the membrane load in direction 2 was  $E_{2m} = 2.562$  GPa. The modulus of sliding for the orthotropic plate was the same as for the isotropic plate  $G_{12} = 68.9$  GPa.

To obtain the reduced values of the elasticity modulus according to bending, the model of the plate was loaded with the pressure normal to the middle surface with the intensity equal to the pressure intensity in the case of membrane wall. Supports and calculated deformation field are presented in fig. 2(b). The deflection of the middle point was calculated as 2.59 mm, while the corresponding deflection of the panel model in the case of the supports along direction 2 was 1.80 mm. The elasticity matrix corresponding to bending was defined applying Poisson's ratios (3). Using linear approximation, the fictive elasticity modulus could be defined according to bending around direction 1 as  $E_{1b} = 263.32$  GPa and the other one as  $E_{2b} = 3.154$  GPa.

For the presented example of the membrane wall, the elasticity matrixes for membrane and bending load have the following forms

$$\begin{bmatrix} 213.9 & 0.87 & 0 \\ 0.87 & 2.562 & 0 \\ 0 & 0 & 68.9 \end{bmatrix} \text{ GPa}, \quad \begin{bmatrix} 263.67 & 1.055 & 0 \\ 1.055 & 3.16 & 0 \\ 0 & 0 & 68.9 \end{bmatrix} \text{ GPa} \quad (4)$$

*Verification of a new sub-type of finite element*

Comparison of the results obtained by parallel calculation of pressure on orthotropic plate thickness 30 mm and membrane wall was done (fig. 3). Parallel calculation gave the results presented in Table 3.

**Table 3. Deflection and stress of the wall and the plate thickness 3 cm**

FEM model	Middle point deflection	Maximal eqv. stress
Membrane wall	1.53 mm	289 MPa
Plate thickness 3 cm	1.58 mm	225 MPa

The equivalent stress was obtained using the Huber-Hancky-Misses hypothesis.

The difference in panel and plate deflections was only about 3%, which was expected because the reduction was done according to deformation fields. Stress field in the plate case is mean relative to the panel case. Since using the reduced-plate FEM model stress concentration could not be detected, calculated results had to be increased by 30%.

To compare the other part, load the wall and the plate with forces in direction 1 of 500 kN in total and decrease forces in direction 2 by 100 times. Comparative results obtained for membrane load are presented in Table 4. Equivalent stress for the case of membrane wall is presented in fig. 4. Maximal stress in the panel is the same as the stress in the plate, however, in the plate the stress is constant.

This new subtype of finite element was defined in the software package KOMIPS [15, 16]. It is a finite element with two thicknesses and two elasticity matrixes. The first thickness and first matrix correspond to the membrane load and the second ones to the bending load.

#### Finite element model of global boiler construction

The following calculation presents the stress and strain state of the steam water - tube boiler processed by Minel Kotlogradnja Belgrade [17] with maximal permanent steam production of 110 t/h. The global dimensions of the boiler were: length 9104 mm, width 4896 mm. The upper (steam) drum was placed at 13475 mm height and had external radius of  $\varnothing 1700$  mm. The lower (water) drum was at 2500 mm height with the external diameter  $\varnothing 1000$  mm. The boiler had buckstays on the lateral walls at 5548 mm and 9148 mm height.

The boiler consisted of the main structures as follows: membrane walls (exposed evaporator), collectors, tube colander, convectional evaporator, upper drum, lower drum, super-heater, economizer, buckstay system, steel-construction with galleries. Steam super-heater was of a bilateral type and could be analyzed as an individual part.

The basic geometry of the global boiler model is presented in fig. 5. The model was formed using 8385 nodal points, 3747 beam and 5638 plate finite elements.

The calculation was done for over-pressure of 55 bar in the upper drum and 55.8 bar in the lower drum. Over-pressure of 23.4 mbar was adopted for the chamber, while temperatures of the constructive parts were adopted according to EN norms and SRPS M.E2.030. So, the assumed temperature of the exposed walls was 321°C and of the convective evaporator 296 °C. The adopted temperature of the walls was 271°C.

**Table 4. Comparative stress and displacement results**

	Membrane wall	Plate thickness 1cm
Longitudinal displacement	0.229 mm	0.233 mm
Transversal displacement	0.0135 mm	0.0108 mm
Maximal equivalent stress	81.4 MPa	81.4 MPa

Deformation of the construction is shown in fig. 6. Maximal calculated value was 49 mm, while the obtained value for the model without buckstays was 108 mm. Buckstays reduced deformations of the membrane-walls by 50%. Thermal load had dominant influence on the deformation field.

Stress field in the plates of the model is presented in fig. 7. Maximal stress based on thermal and pressure load of 199 MPa was located in the horizontal plates of the buckstays, in

the boiler corners. In the lateral walls, stress concentration gave the value of 170 MPa. In the membrane walls near the boiler corners the stress was about 160 MPa and the value of the maximal obtained stress in the beams was 130 MPa. A detailed stress and strain analysis of this water-tube boiler construction was presented in [18].

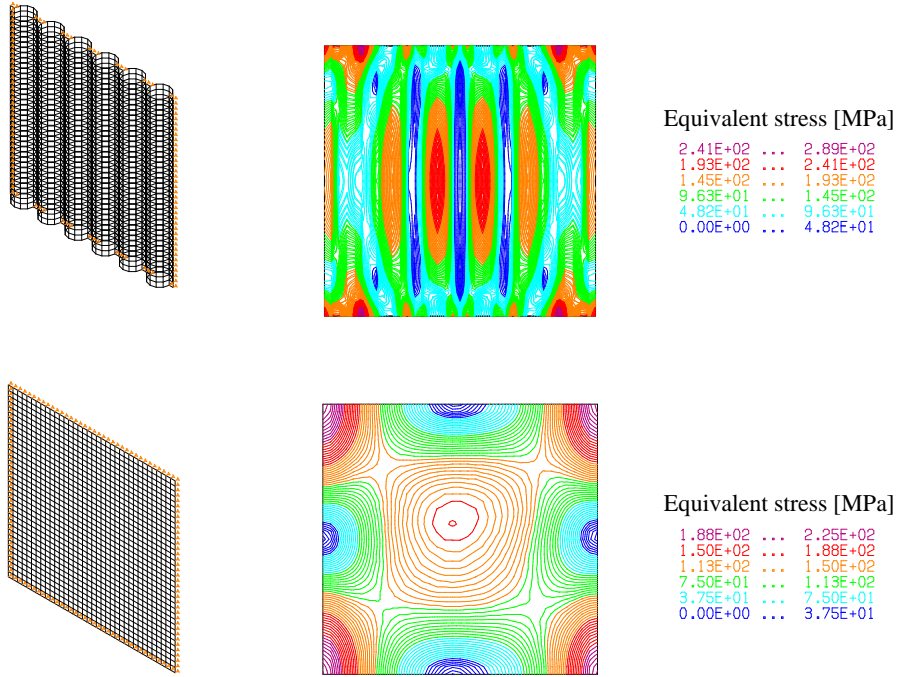

**Figure 3. FEM models, pressure load, stress fields**

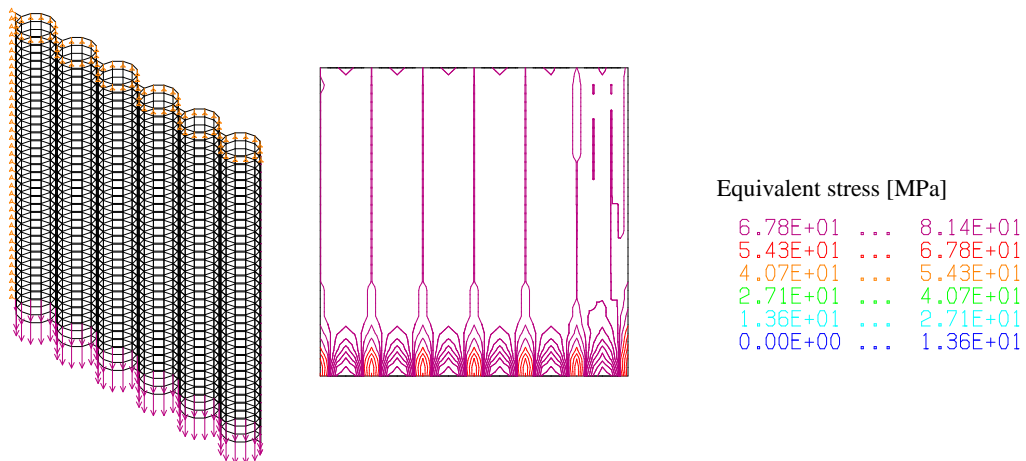

**Figure 4. Membrane wall**

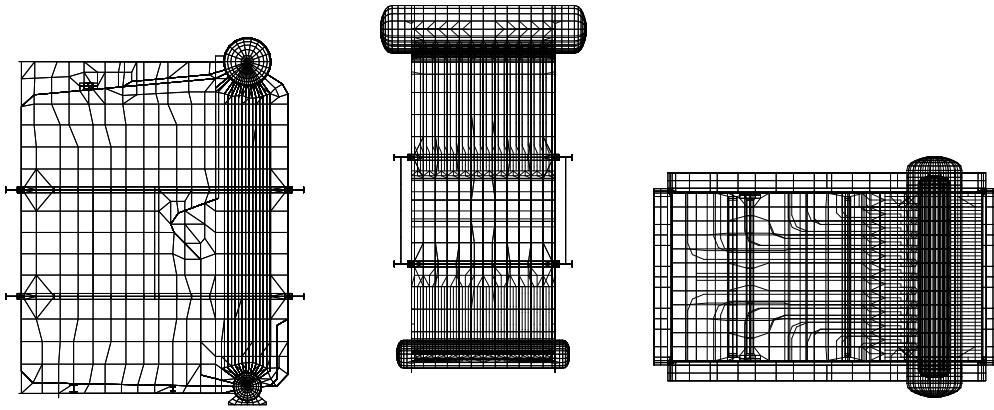

Figure 5. FEM model of the boiler construction

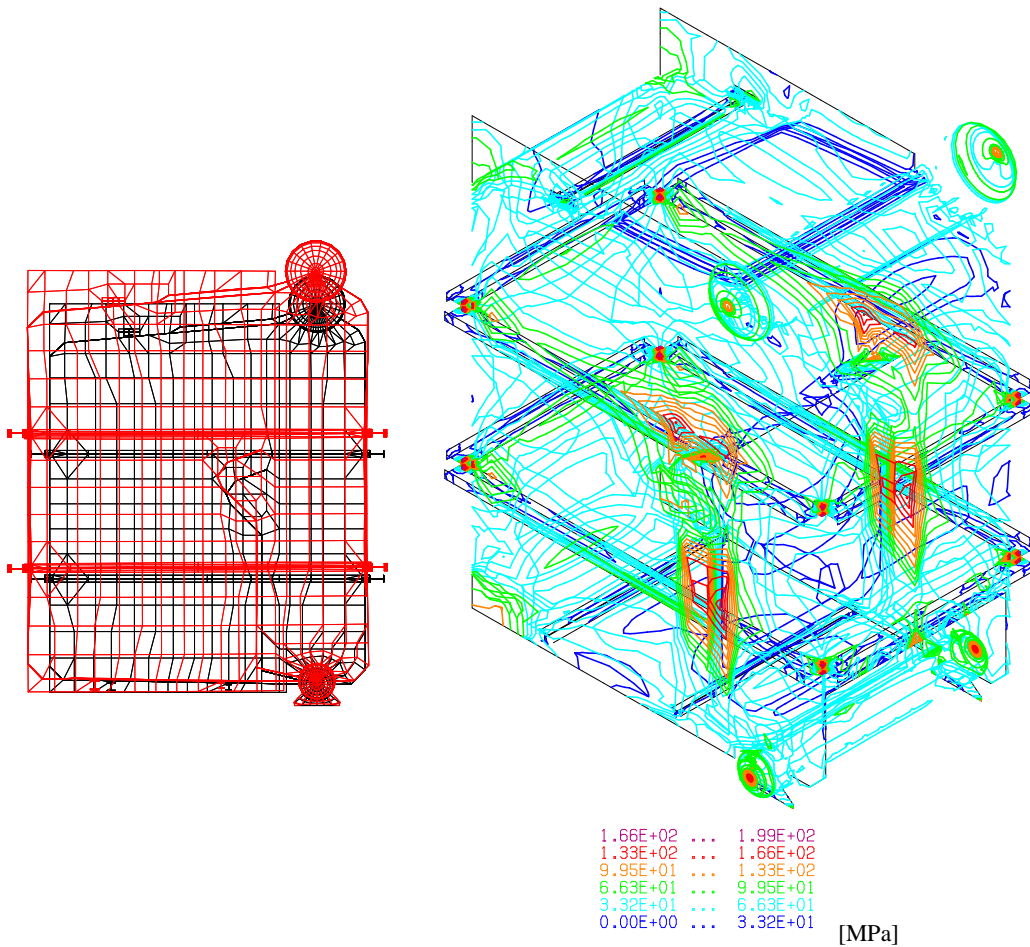
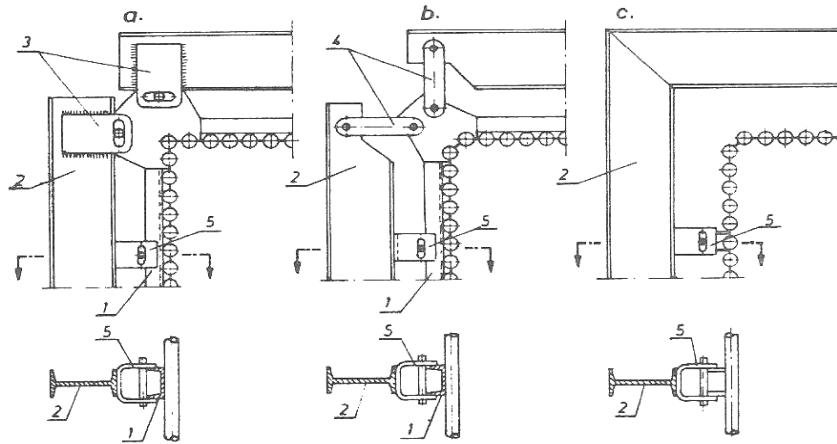

Figure 6. Deformation of the plate elements

Figure 7. Equivalent stress

### Buckstay system of membrane walls

Membrane walls are geometrically orthotropic plates with, as explained, a large difference in stiffness in two normal directions. So, the buckstay system is needed to decrease deformations due to over-pressure [19]. Buckstay consists of internal (fig. 8, item 1) and external part (item 2). Their connection insures the possibility of free dilatations. Internal part is placed under the isolation and its temperature is commonly lower than the temperature of membrane wall. External part is usually I-cross-section beam placed perpendicular to the membrane wall. Their connections have been established in several ways [19] and the most popular versions are presented in fig. 8.

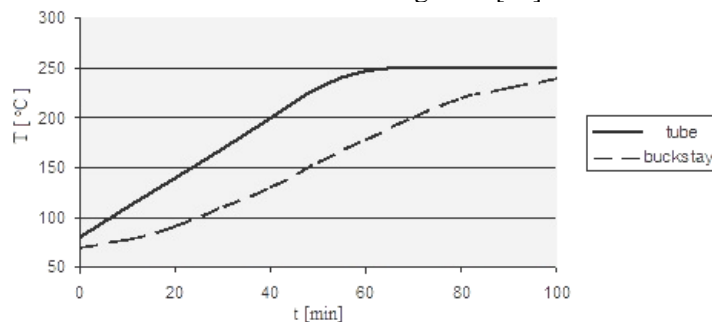

**Figure 8. Construction of the angular part of the membrane wall**

- 1 – Internal buckstay 2 – External buckstay 3 – Connecting slider of external buckstays
- 4 – Joint of external buckstays 5 – Connecting slider for external and internal buckstay

Water-tube boiler with the membrane chamber usually has failure in the angular sections of the membrane wall near the buckstay position. The failures occur due to a large difference in temperature during the start and the stop regimes. So, the flexibility of the membrane wall corners is necessary to prevent failures and cracks in welding zones.

During the start regime of the boiler, internal buckstay is heated more slowly than the tubes (fig. 9). In rapid heating, there is a high temperature difference between the membrane wall and internal buckstay, which provides large internal stresses. Figure 10 presents temperature differences for various heating rates [19].



**Figure 9. Temperature of membrane wall and internal buckstay as a function of time**

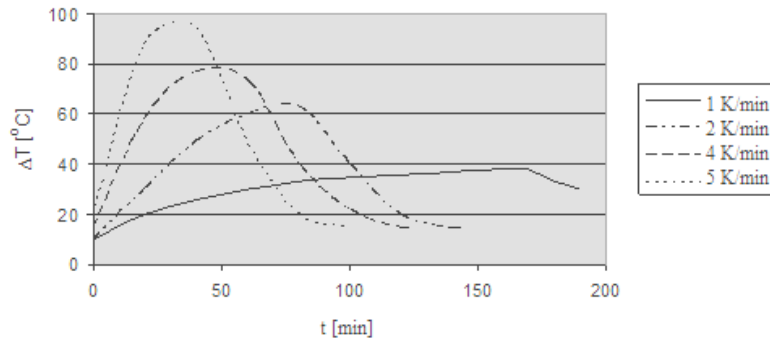

**Figure 10. Temperature differences between membrane wall and internal buckstay as a function of time and heated velocities**

Temperature field in membrane walls of the chamber is not uniform. There is a large difference between the tube part placed in the chamber and the part placed in the boiler sheath; temperature on the internal tube radius is not the same as the temperature on the external radius; there is also difference in temperature on the welds between tubes and flanges. Non-uniform temperature distribution induces thermal stresses in membrane walls. High level of local stresses occurs in walls as a consequence of inhibition of their deformations. The FEM is reliable in the solution of the discontinuity problem.

### **FEM models of membrane walls and buckstay system**

#### *Detailed and reduced model*

The buckstay system on the boiler VU60 presented in Section 3 corresponds to the system presented in fig. 8c. The internal part consists of steel flanges. The external part of buckstay is I cross-section beam.

In the analysis presented in section “Finite element model of global boiler construction”, a global boiler model was formed using finite elements of reduced orthotropic plate. A high level of stress of 199 MPa was detected in plates of buckstays close to boiler corners.

For detailed analysis of this problem two FEM models were formed designated as M1 and M2. The length of 4386 mm and the width of 3672 mm of membrane walls were chosen. The symmetry of the geometry and the loads was adopted.

In model M1 tubes and flanges of the membrane wall were formed using plate finite element. The model was formed on 16253 nodal points and 16934 beam and plate elements. The load consisted of the gas pressure from the chamber, internal pressure in tubes and temperature.

Maximal calculated deformation was 3.6 mm. Stress field in the plates of model M1 is presented in fig. 11. Maximal equivalent stress of 140 MPa is located in corner plates of the buckstays. In the corner tube on the part located in the sheath stress concentration is 85 MPa.

Membrane walls in model M2 were formed using finite elements of reduced orthotropic plate with presented elasticity matrixes.

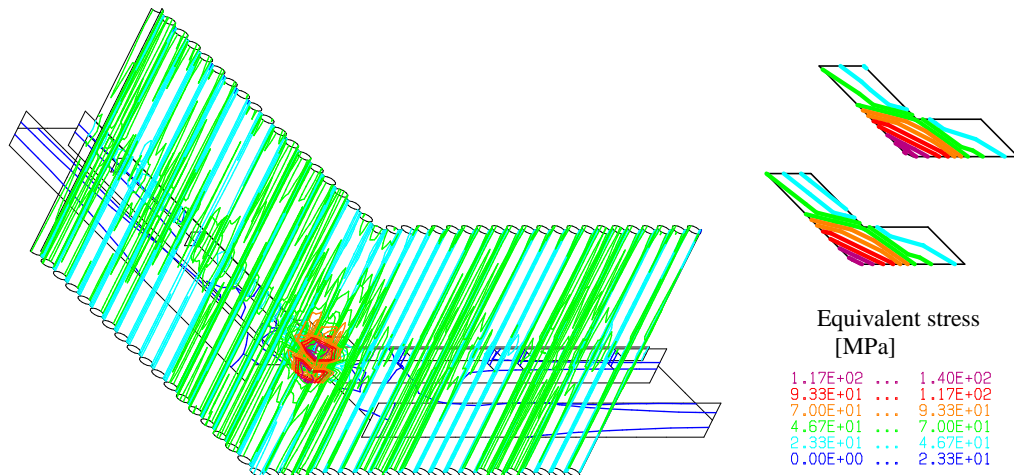
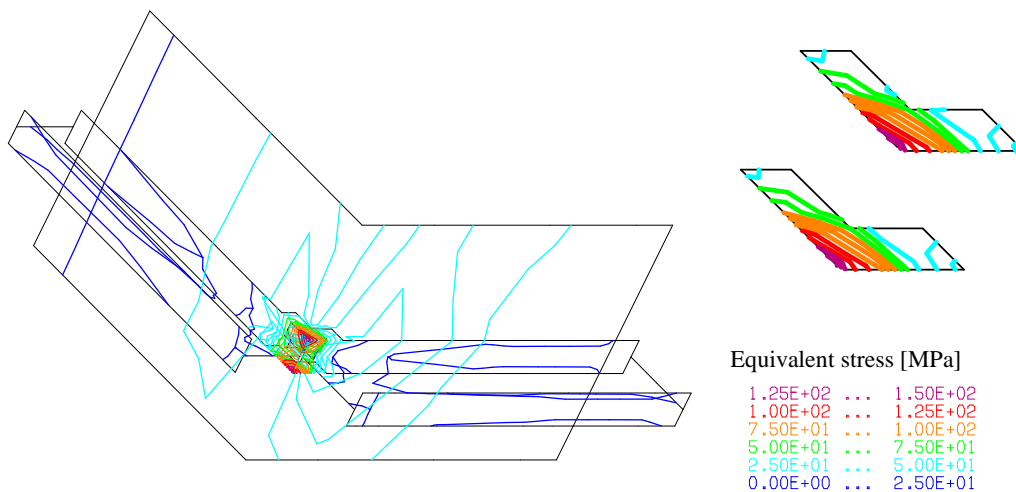

**Figure 11. Stress field in membrane wall and in corner plates of buckstays. Model M1**

The model M2 consists of only 206 nodal points and 223 elements. Maximal obtained deformation was the same as in previous case 3.5 mm. Stress field is shown in fig. 12. Maximal calculated equivalent stress was 150 MPa in the corner plates of the buckstays. In the corner of the membrane wall stress concentration was 75 MPa.

**Table 5. Obtained results for models M1 and M2**

Model	M1	M2
Node number	16253	206
Element number	16934	223
Maximal equivalent stress	140 MPa	150 MPa
Stress in membrane wall	85 MPa	75 MPa



**Figure 12. Stress field in model M2**

As presented, two local finite element models were formed:

- a detailed model M1 with tubes and flanges modeled using plate finite element, and
- a reduced model M2 with membrane walls modeled using finite element of reduced orthotropic plate.

Both models had the same dimensions and the same boundary conditions. Obtained results for maximal equivalent stress in the plates of the corner part of buckstays were similar, but less than the value calculated using a global boiler model. Figures 11 and 12 provided the proof for the defined finite element of reduced orthotropic plate with two thicknesses.

Numbers presented in Table 5 show that the difference in the results for the models is only about 7 percent. At the same time, the number of nodes and elements in model M2 is about 80 times less than that in the detailed model M1. The first conclusion is that the new finite element is quite suitable for boiler calculations.

#### *Reduced local model close to the global model*

Both local models presented in the previous Section gave the values of maximal stress in membrane walls lower than the values obtained for the global model shown in section “Finite element model of global boiler construction”. So, the influence of the global boiler geometry was not taken in an appropriate way in the local models M1 and M2. The problem was solved using the other model, M3, presented in fig. 13. As the finite element of reduced orthotropic plate was suitable for calculation, one half of the front and one half of the right membrane wall were formed based on previous calculation. The symmetry of the geometry and loads was adopted. The length of membrane walls was adopted to be from the floor to the level of the upper part of the buckstay system.

**Table 6. Obtained results from global model M and local model M3**

	<b>Global model M</b>	<b>Local reduced model M3</b>
Node number	8385	305
Element number	9385	318
Maximal equivalent stress	199 MPa	210 MPa
Stress in membrane walls	160 MPa	160 MPa

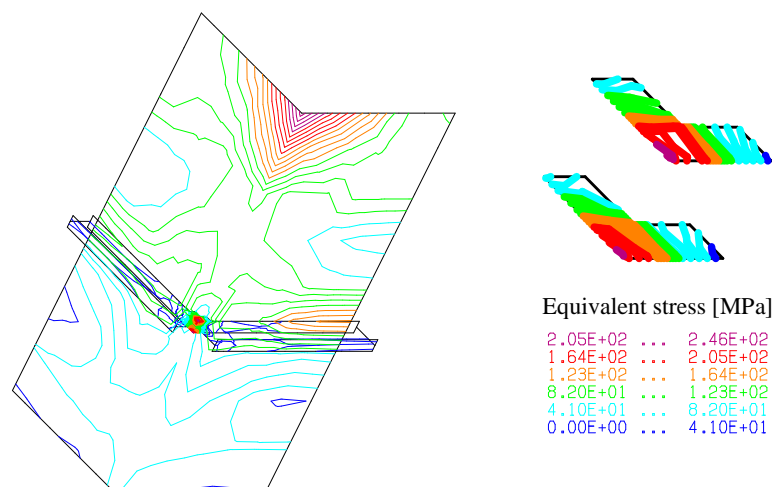

**Figure 13. Deformation and stress calculated from model M3**

Deformation of the plate elements of local reduced model M3 with corresponding supports is presented in fig. 13 as the obtained stress field. Model M3 consists of only 305 nodal points and 318 finite elements. The calculated maximal equivalent stress in the corner plates of buckstays was 210 MPa, while the corresponding stress in the corner of membrane walls was 160 MPa. Global model M gave similar stress values, as presented in Table 6.

It is important that at the same time the ratio of node and element number for both models was about 30.

## Conclusions

The analysis presented above demonstrated that the reduced local model is the most suitable model for stress and strain analysis of chamber membrane walls without global modeling of the boiler construction. This model can be used for the design of buckstay system. Norms do not consider the unpressurized elements like buckstays, so the designers have to take into consideration other methods such as FEM. In the design of buckstay system, the corresponding FEM analysis can be applied using the global boiler model or the adopted local model. The entire calculation procedure is presented in the paper. Initially, the finite element of reduced orthotropic plate was obtained. Plate thicknesses corresponding to the membrane and bending load, together with the corresponding elasticity matrixes, were defined. As presented, the model based on this finite element was relatively simple and suitable for fast calculation.

In some types of boilers, in the upper part of the chamber, static pressure is equal to atmospheric pressure. In this case, intermediate disturbances can provide high over- or under-pressure and the occurrence of failure. Consideration of the buckstay system has to involve this system to insure construction integrity. Provided analysis is valid for elastic state of material. When the calculated equivalent stress is close to yield stress, plastic deformations and cracks can be expected.

## Acknowledgement

This work is a contribution to the Ministry of Education, Science and Technological Development of Serbia funded projects TR 35040 and TR 35011.

## References

- [1] Taljat, B., Zacharia, T., Wang, L., Keiser, J. R., Swindeman, R. W., Hubbard, C. R., Mechanical design of steel tubing for use in black liquor recovery boiler: a look at how finite element analysis methods can evaluate stress conditions, *Pulp & Paper (Canada)*, 100 (1999), 10, pp. 34-38
- [2] Mac Lean, K., Fournier, E., Gomez-Grande, J., Scandrolì, T., The "World's Largest" Inconel Waterwall Weld Overlay, *Power Engineering (Barrington)*, 113 (2010), 11, pp. 174
- [3] Šijački Žeravčić, V., Bakić, G., Đukić, M., Andjelić, B., Analysis of test results of hot-water boiler as a basic for its integrity assessment, *Structural Integrity and Life*, 7 (2007), 2, pp.133-140
- [4] Othman, H., Purbolaksono, J., Ahmad, B., Failure Investigation on Deformed Superheater Tubes, *Engineering Failure Analysis*, 16 (2009), 1, pp. 329-339
- [5] Caligiuri, R., Foulds, J., Sire, R., Andrew S., Thermal Constraint Consideration in Design of a Heat Recovery Boiler, *Engineering Failure Analysis*, 13 (2006), 8, pp. 1388-1396
- [6] Gaćeša, B., Milošević-Mitić, V., Maneski, T., Kozak, D., Sertic, J., Numerical and Experimental Strength Analysis of Fire-Tube Boiler Construction, *Technical Gazette*, 18 (2011), 2, pp. 237-242
- [7] Arsić, M., Aleksić, V., Hut, N., Analysis of state and integrity assessment of boilers – Structural performance diagnostics, *Structural Integrity and Life*, 5 (2005), 1, pp. 3-17
- [8] Mitrović, R., Momčilović, D., Erić, O., Atanasovska, I., Hut, N., Study on Impact properties of Creep-Resistant Steel Thermally Simulated Heat Affected Zone, *Thermal Science*, 16 (2012), 2, pp. 513-525

- [9] Kalaba, D., Sedmak, A., Radaković, Z., Miloš, M., Thermomechanical modeling of the resistance welding of PbSb Alloy, *Thermal Science*, 14 (2010), 2, pp. 437-450
- [10] Gaćeša, B., Maneski, T., Milošević-Mitić, V., Condition and Behavior Diagnostics of Boiler Constructions, *FME Transactions*, 40 (2012), 2, pp. 87-92
- [11] Mijuca, D., Žiberna, A., Medjo, B., A new multifield finite element method in steady state heat analysis, *Thermal Science*, 9 (2009), 1, pp. 111-130
- [12] Maneski, T., Milosevic-Mitic, V., Gacesa, B., Problems in the Modeling of Steam Boilers, *Proceedings (Šumarac, Kuzmanović)*, 1<sup>st</sup> Int. Cong. of Serbian Soc. of Mech. 2007, pp. 451-456
- [13] Tomić, R., Sedmak, A., Čatić, D., Miloš, M., Stefanović, Z., Thermal stress analysis of a fiber-epoxy composite material, *Thermal Science*, 15 (2011), 2, pp. 559-563
- [14] Gipson, R.F., Principles of Composite Material Mechanics, McGraw-Hill Companies, New York, 1994
- [15] Maneski, T., Computer modeling and calculation of structures, Faculty of Mechanical Engineering, Belgrade, Serbia, 1998
- [16] Maneski, T., Milošević-Mitić, V., Numerical and experimental diagnostics of structural strength, *Structural Integrity and Life*, 10 (2010), 1, pp. 3-10
- [17] Gaćeša, B., Numerical and experimental strength analysis of boiler constructions (in Serbian), Ph. D. Thesis, Faculty of Mechanical Engineering, University of Belgrade, Serbia, 2011
- [18] Milošević-Mitić, V., Gaćeša, B., Andjelić, N., Maneski, T., Numerical calculation of the water tube boiler using finite element of the orthotropic plate, *Structural Integrity and Life*, 12 (2012), 3, pp. 185-190
- [19] Gulić, M., Brkić, Lj., Perunović, P., Steam boilers (in Serbian), Faculty of Mechanical Engineering, Belgrade, Serbia, 1988